



TESA
TECHNOLOGY

Instruction manual

MEASURING STATION

TESA μ -HITE



This document is confidential and only to be used internally by the company that has purchased the measuring station mentioned above. Before duplicating or transmitting it to third parties without any connection to the use of these instruments, an official request has to be sent to TESA SA.

Copyright TESA, Version 3.2, November 2023

TABLE OF CONTENTS



If you are using the PDF version of this document, you can directly access the required chapter by clicking on the respective line of the table of contents.

| | | |
|----------|------------------------------------------------------|-----------|
| 1 | INTRODUCTION | 7 |
| 1.1 | Acknowledgements | 7 |
| 1.2 | Warning | 7 |
| 1.3 | Copyright (document) | 7 |
| 1.4 | Copyright (software) | 7 |
| 1.5 | Preamble | 7 |
| 1.6 | Symbols | 7 |
| 2 | PRESENTATION..... | 8 |
| 2.1 | General description | 8 |
| 2.2 | Electric power supply | 9 |
| 2.3 | Measuring system | 9 |
| 2.4 | Control panel..... | 11 |
| 2.5 | Interface & displayed values | 11 |
| 2.6 | Printer..... | 11 |
| 2.7 | Connectors | 12 |
| 3 | TECHNICAL SPECIFICATIONS..... | 13 |
| 4 | DELIVERY CONTENTS | 15 |
| 4.1 | System components | 15 |
| 4.2 | Packaging | 15 |
| 4.3 | Calibration certificate | 16 |
| 5 | INSTALLATION, SECURITY & MAINTENANCE..... | 18 |
| 5.1 | Location..... | 18 |
| 5.2 | Place of use | 18 |
| 5.3 | Lighting..... | 18 |
| 5.4 | Measuring surface | 18 |
| 5.5 | Cleanliness..... | 18 |
| 5.6 | Vibrations | 18 |
| 5.7 | Electric power supply | 18 |
| 5.8 | Maintenance of the Masterpiece | 18 |
| 5.9 | Final use..... | 18 |
| 5.10 | Storage..... | 19 |
| 5.11 | Cleaning | 19 |
| 5.12 | Opening elements | 19 |
| 5.13 | Recycling..... | 19 |
| 6 | INSTALLATION | 20 |
| 6.1 | Packaging | 20 |
| 6.2 | Unpacking & installation..... | 21 |
| 6.3 | Printer installation..... | 31 |
| 6.4 | Pedal installation | 31 |
| 7 | CONTROL PANEL..... | 33 |
| 7.1 | General description | 33 |
| 7.2 | Touchscreen | 34 |
| 7.3 | Measurement zone | 34 |
| 7.4 | Calculation zone..... | 34 |
| 7.5 | Software navigation | 34 |

| | | |
|-----------|--------------------------------------------------|-----------|
| 7.6 | Context-based actions | 36 |
| 8 | MEASUREMENT INTERFACE | 37 |
| 8.1 | Status bar | 37 |
| 8.2 | Main zone | 37 |
| 8.3 | Trigger force | 38 |
| 8.4 | Context-based actions bar | 38 |
| 8.5 | Measurements list | 38 |
| 8.6 | Location | 39 |
| 9 | SYSTEM OPTIONS | 41 |
| 9.1 | Access | 41 |
| 9.2 | System configuration | 41 |
| 9.3 | Measurement parameters 1 | 42 |
| 9.4 | Measurement parameters 2 | 43 |
| 9.5 | Input/outputs | 45 |
| 9.6 | Tolerances | 46 |
| 9.7 | Temperature | 47 |
| 9.8 | Results & reports | 47 |
| 9.9 | Languages | 48 |
| 9.10 | Customised language | 48 |
| 10 | INITIALISATION | 49 |
| 10.1 | Concept | 49 |
| 10.2 | Process | 49 |
| 11 | DETERMINATION OF THE PROBE CONSTANT | 50 |
| 11.1 | Masterpiece | 50 |
| 11.2 | Maintenance of the Masterpiece | 50 |
| 11.3 | Concept | 51 |
| 11.4 | Procedure | 52 |
| 11.5 | Steps | 53 |
| 12 | PRINCIPLES OF MEASUREMENT | 55 |
| 12.1 | Generality | 55 |
| 12.2 | Probe support | 55 |
| 12.3 | Measurement modes | 56 |
| 12.4 | ST1 & ST2 philosophy | 56 |
| 12.5 | Measurement functions | 57 |
| 12.6 | Single probing | 59 |
| 12.7 | Culmination point measurement | 60 |
| 12.8 | Bore measurement | 62 |
| 13 | ST1 MODE | 64 |
| 13.1 | Generality | 64 |
| 13.2 | Capturing the reference value | 65 |
| 13.3 | Reference value management | 66 |
| 13.4 | Secondary functions FX | 66 |
| 13.5 | Context-based actions | 66 |
| 14 | ST2 MODE | 67 |
| 14.1 | Generality | 67 |
| 14.2 | Probe calibration | 67 |
| 14.3 | Capturing the reference value | 67 |
| 14.4 | Single & double probing | 68 |
| 14.5 | Secondary results | 70 |
| 14.6 | Secondary functions FX | 71 |
| 14.7 | Indirect reference (PRESET) | 71 |
| 14.8 | A&B references management | 71 |

| | | |
|-----------|-----------------------------------------------------------------|------------|
| 14.9 | Delete last measurement block..... | 72 |
| 14.10 | Edit a measurement block | 72 |
| 14.11 | To run a probe calibration | 72 |
| 14.12 | Distance between two heights | 73 |
| 14.13 | Average between two heights..... | 73 |
| 14.14 | Selection of a measurement block..... | 73 |
| 14.15 | Two measurement blocks selection..... | 74 |
| 15 | MAX, MIN, Δ MODE..... | 75 |
| 15.1 | Introduction | 75 |
| 15.2 | Measurement principle..... | 75 |
| 15.3 | Graphic..... | 77 |
| 16 | ANGLE MEASUREMENT | 78 |
| 16.1 | Introduction | 78 |
| 16.2 | Measurement principle..... | 79 |
| 16.3 | Cone angle measurement..... | 80 |
| 17 | CALCULATOR..... | 81 |
| 17.1 | General information | 81 |
| 17.2 | Concept..... | 81 |
| 17.3 | Use of the measurement blocks | 82 |
| 17.4 | Changing measurements list | 82 |
| 17.5 | Customised calculation function | 83 |
| 18 | MODE 2D | 84 |
| 18.1 | Introduction | 84 |
| 18.2 | Principle | 84 |
| 18.3 | Two measurement possibilities..... | 85 |
| 18.4 | Application examples | 87 |
| 18.5 | Step by step example | 87 |
| 18.6 | Results analysis | 91 |
| 18.7 | To define a datum | 91 |
| 18.8 | Where is the current datum?..... | 92 |
| 18.9 | To change the coordinates system..... | 93 |
| 18.10 | To define an origin | 93 |
| 18.11 | To define a reference axis | 93 |
| 18.12 | Midpoint..... | 93 |
| 18.13 | Intersection of two lines | 94 |
| 18.14 | Line through 2 points | 94 |
| 18.15 | Bestfit line..... | 94 |
| 18.16 | Circle through 3 points | 94 |
| 18.17 | Bestfit circle..... | 95 |
| 18.18 | Distance between 2 points..... | 95 |
| 18.19 | Angle by 3 points | 95 |
| 18.20 | Angle between two lines | 95 |
| 18.21 | Angle with a datum axis..... | 96 |
| 18.22 | Perpendicular distance | 96 |
| 18.23 | To create a virtual point | 96 |
| 18.24 | To create a virtual circle..... | 97 |
| 18.25 | Origin translation..... | 97 |
| 18.26 | Datum rotation..... | 99 |
| 18.27 | How do you include a 2D result in a measurement sequence? | 99 |
| 19 | DATA MANAGEMENT..... | 102 |
| 19.1 | Generality..... | 102 |
| 19.2 | Automatic or manual transmission..... | 102 |
| 19.3 | Transmission format | 103 |

| | | |
|-------------------------------------------|----------------------------------------------------------|------------|
| 19.4 | Transmission via TLC (cable) | 104 |
| 19.5 | Transmission via TLC (wireless)..... | 105 |
| 19.6 | Use of the printer..... | 105 |
| 19.7 | *.pdf report | 105 |
| 19.8 | Annotate your measurement program | 107 |
| 19.9 | Screenshot..... | 108 |
| 20 | PROGRAM MANAGEMENT..... | 109 |
| 20.1 | Introduction | 109 |
| 20.2 | Program creation..... | 109 |
| 20.3 | Insert tolerances..... | 109 |
| 20.4 | Tolerancing with ISO table..... | 111 |
| 20.5 | To save a sequence..... | 111 |
| 20.6 | Sequence loading | 112 |
| 20.7 | To run a sequence | 113 |
| 20.8 | To pause a sequence run | 115 |
| 20.9 | To re-measure a block..... | 115 |
| 20.10 | Timer..... | 115 |
| 20.11 | Results | 117 |
| 20.12 | To run a sequence in loop | 117 |
| 20.13 | Probe calibration block & run the sequence in loop | 117 |
| 20.14 | Reference block & run the sequence in loop..... | 117 |
| 21 | CONTROL AND UPDATE | 119 |
| 21.1 | Generalities | 119 |
| 21.2 | System information | 119 |
| 21.3 | Control of the system..... | 120 |
| 21.4 | Sensor control..... | 120 |
| 21.5 | Reference mark control..... | 120 |
| 21.6 | Software update..... | 120 |
| 22 | CONTEXTUAL ACTIONS..... | 123 |
| 22.1 | General actions | 123 |
| 22.2 | Actions regarding <i>ST1</i> & <i>ST2</i> modes | 124 |
| 22.3 | Actions regarding <i>Angle</i> mode..... | 124 |
| 22.4 | Actions regarding <i>Min, max, Δ</i> mode..... | 124 |
| 22.5 | Actions regarding 2D mode | 124 |
| 22.6 | Actions regarding <i>Calculator</i> mode..... | 125 |
| OPTIONAL ACCESSORIES: | | 126 |
| DECLARATION OF CONFORMITY EU | | 127 |

1 INTRODUCTION

1.1 Acknowledgements

Dear user,

We would like to thank you for having chosen TESA as your metrology partner. We thank you for your confidence in purchasing our measuring station the TESA μ -HITE.

Your metrological concerns are important to us, and we are convinced that this instrument will meet your expectations. We are constantly striving to develop solutions adjusted to your needs.

The result? Your satisfaction for many years. Our pleasure? To know that our products help you meet your needs in research, development, and production in a quick and efficient way, and for a long time.

The whole TESA team welcomes you to our family of TESA product users.

Your TESA team

1.2 Warning

This instruction manual must be read by every technician or operator before the installation, maintenance, or use of the instrument. Not adhering to certain instructions regarding its use could lead to malfunction or deterioration of the instrument.

1.3 Copyright (document)

The content of this document has been created subject to subsequent modifications without prior notice. All modification rights are reserved.

The French version is the reference language. All other language versions are only translations.

1.4 Copyright (software)

The software delivered with the μ -HITE contains copyright-protected software that is licensed under the following open-source licenses:

- MIT: <https://opensource.org/licenses/MIT>
- CDDL: <https://opensource.org/licenses/cddl1.php>
- CPOL: <http://www.codeproject.com/info/cpol10.aspx>
- LGPLv2: <https://opensource.org/licenses/LGPL-2.1>

For more information, please contact your local representative.



1.5 Preamble

The μ -HITE measuring station is the result of more than 70 years of experience in the conception and production of high-precision measurement equipment. It has been designed to meet the needs of a production environment and to offer its users an affordable, quick, and precise way for dimensional control of small or large workpieces in workshops or laboratories.

This document describes the different procedures to be followed in order to allow for a quick and easy handling of your motorised measuring station.

1.6 Symbols

Several different types of symbols are used in this manual. They give important information that has to be considered in order to correctly use the measuring instrument.

| Position | Description |
|-------------------------------------------------------------------------------------|-------------------------------------------------------------------------------|
|  | Not adhering to these instructions can lead to incorrect measurement results. |
|  | Corresponds to an assistance for better use. |

2 PRESENTATION

2.1 General description

The TESA μ -HITE measuring station is different from any other height gauge as it offers an exceptional performance as well as intuitive and easy use.

This autonomous measuring instrument is designed for measuring lengths such as external, internal, step, height, or depth dimensions as well as distances.

A massive granite table including a steel pole form the station base on which the probing head will be fixed thanks to a special cast iron support.

Under the protective housing we can find a rigid vertical part, equipped with a guiding part on which the measuring head slides onto. Its displacements are detected by an optoelectronic measuring system (patented by TESA).

The instrument is used with a control panel with numerous calculation possibilities offering a measuring solution adjusted to each application.

| N° | Description |
|----|---------------------------------------------------------|
| 1 | Granite table |
| 2 | Probe support + probe |
| 3 | Electronic system reading the position (sensor + scale) |
| 4 | Protective housing |
| 5 | Pole |
| 6 | Probing head support |
| 7 | Adaptation box-probing head connection cable |
| 8 | Touchscreen |
| 9 | Panel |
| 10 | Adaptation box |



2.2 Electric power supply

The instrument should be powered only by using the device supplied: TESA reference 00760251.



It is important to only always use the cable and power supply unit provided with the instrument (TESA reference mentioned above). Not adhering to these instructions can lead to malfunction of your instrument or irreversibly damage it.

In case of questions, please contact your local reseller.

2.3 Measuring system

The gauge features an optoelectronic measuring system digitally capturing the measured length, which is also called measurand (TESA patent). The glass scale with both incremental graduations and a reference mark serves as materialized measure. According to a principle of reflection, the scale is scanned by a sensor with no mechanical contact. The measuring signal is then transmitted to the control panel.

From the neutral position A, the system for determining the measured values can move in both directions up to the switch points. As soon as one of the two points is reached, it starts capturing and the information is sent to the control panel.



In order to guarantee that your gauge is functioning correctly, it is important that the scale and the sensor remain free of any solid or liquid particles that could impede the functioning of the scale.

The distance C, which is symmetrical to the position of the relevant trigger point, is only used for detecting the culmination point when probing cylindrical circular surfaces.

The system for obtaining the measured values can be moved from the neutral position up to the spring-loaded end stops via the distance D. However, too much pressure will lead to an invalid measurement of the point.

The probing force is visible by a coloured bar on the right side of the screen. At any moment, when the probe comes in contact with the workpiece to be measured, this bar is activated and changes its colour according to the applied pressure.

When the probe touches the piece, the bar on the right displays a unique horizontal black mark.

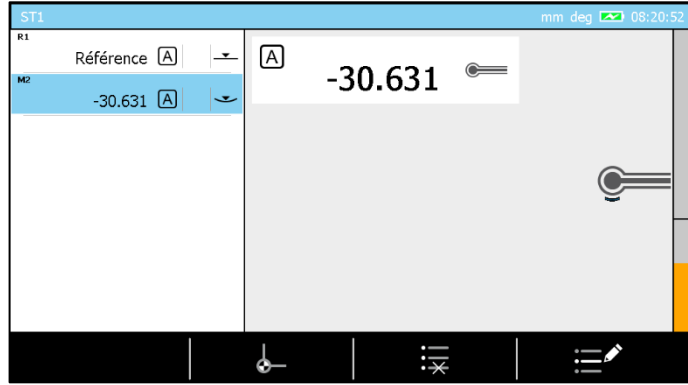

This mark corresponds to the minimum required pressure in order to have a single probing be taken. If the pressure is not high enough, the bar colour is orange. When the mark has been passed by the displayed force, the colour becomes green or even red if the pressure is too high.

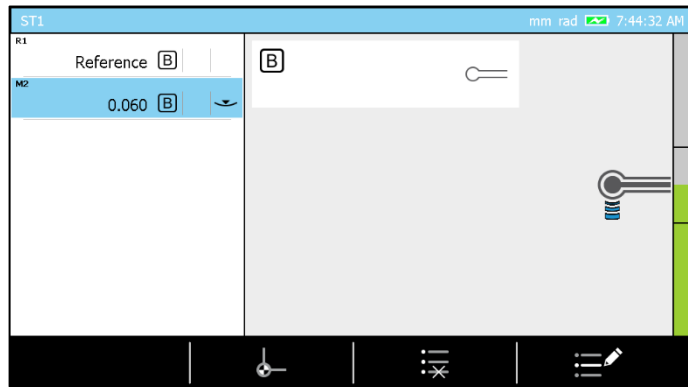

Two horizontal lines are also displayed in the middle of the bar. They represent the ends of the measurement zone defined by letter C in the table below.

| Position | Description |
|----------|--------------------------------------------------------------------------------|
| A | Neutral position |
| B | Travel to the upper (resp. lower) trigger point for determination of the value |
| C | Partial measuring span for detecting the culmination point |
| D | Travel in one direction from the neutral position to the end stops. |

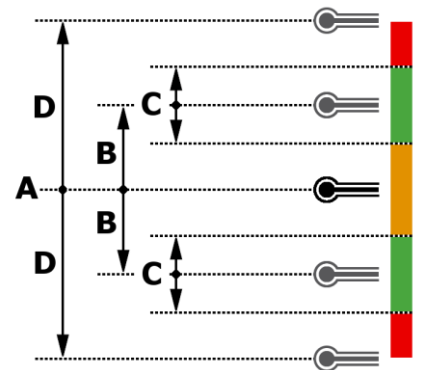

2.4 Control panel

The control panel has been developed as ergonomic and intuitive as possible. Its keyboard is separated in 4 different zones each focusing on particular actions.



For further details, see the chapter corresponding to the control panel keyboard.

2.5 Interface & displayed values

The ergonomic software has been designed to avoid any ambiguous situations. At any time, the displayed values correspond only to a measurement or a calculation and never to the probe position (except in mode “scanning” or *Max*, *Min*, Δ $\frac{\Delta}{\Delta}$).

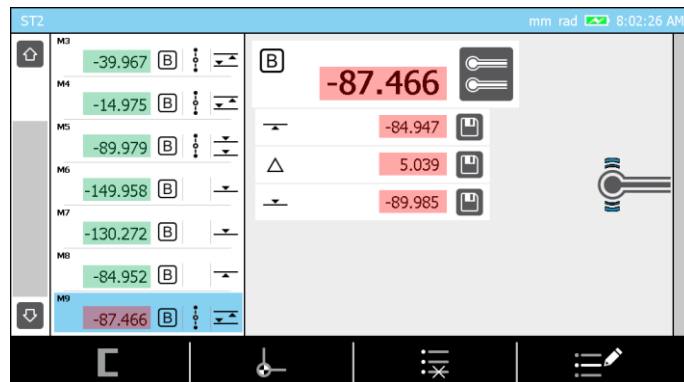

Results of last measurement in red, previous measurement results in green.



In order to avoid any reading errors of the displayed values on the screen, only measurement results or calculations are visible. Except for a few specific modes, your gauge will not display the current value of the position of the probe.

2.6 Printer

An USB matrix printer is available as an optional accessory. Its installation does not require any special intervention. The μ -HITE is directly compatible with this printer, which can be connected to an USB port on the back of the control panel at any time.



For further details on the printer installation see the corresponding chapter.

2.7 Connectors

The control panel features several connectors allowing to manage the obtained data. Besides three USB connectors on the top of the back, there is also a TLC (TESA Link Connector) IP65 connector, which enables you to send data to an external device.



| N° | Description |
|----|-----------------------------------------------------------------------------------------------------|
| 1 | TLC connector (equivalent to standard serial output) |
| 2 | Power supply (not used when the control panel is connected to the height gauge via connector No. 4) |
| 3 | USB connectors |
| 4 | Adaptation box-panel cable connector |

| Series | TESA μ -HITE | |
|-----------------------------------|---------------------------------|---------------------------------|
| Reference | 00730502 | 00730503 |
| Displacement | motorised | motorised |
| Application range [mm] | 100 | 100 |
| Weights [kg] | | |
| • Probe head | 2,5 | 2,5 |
| • Panel | 1,5 | 1,5 |
| • Granite table + pole + support | 16,2 | 16,2 |
| Max. permissible error [μ m] | | |
| • Axial | 1 | 1 |
| • Offset * | 2 | 2 |
| Repeatability [μ m] | | |
| • Axial | 0,5 | 0,5 |
| • Offset * | 1 | 1 |
| Probing force [N] | 0.6 \pm 0.2 1.00 \pm 0.2 | 0.6 \pm 0.2 1.00 \pm 0.2 |
| Resolution [mm] | 0.001 / 0.0001 | 0.001 / 0.0001 |

3 TECHNICAL SPECIFICATIONS



* The above values for the offset probe are valid only if the probe is positioned in the axis of the MU-HITE.

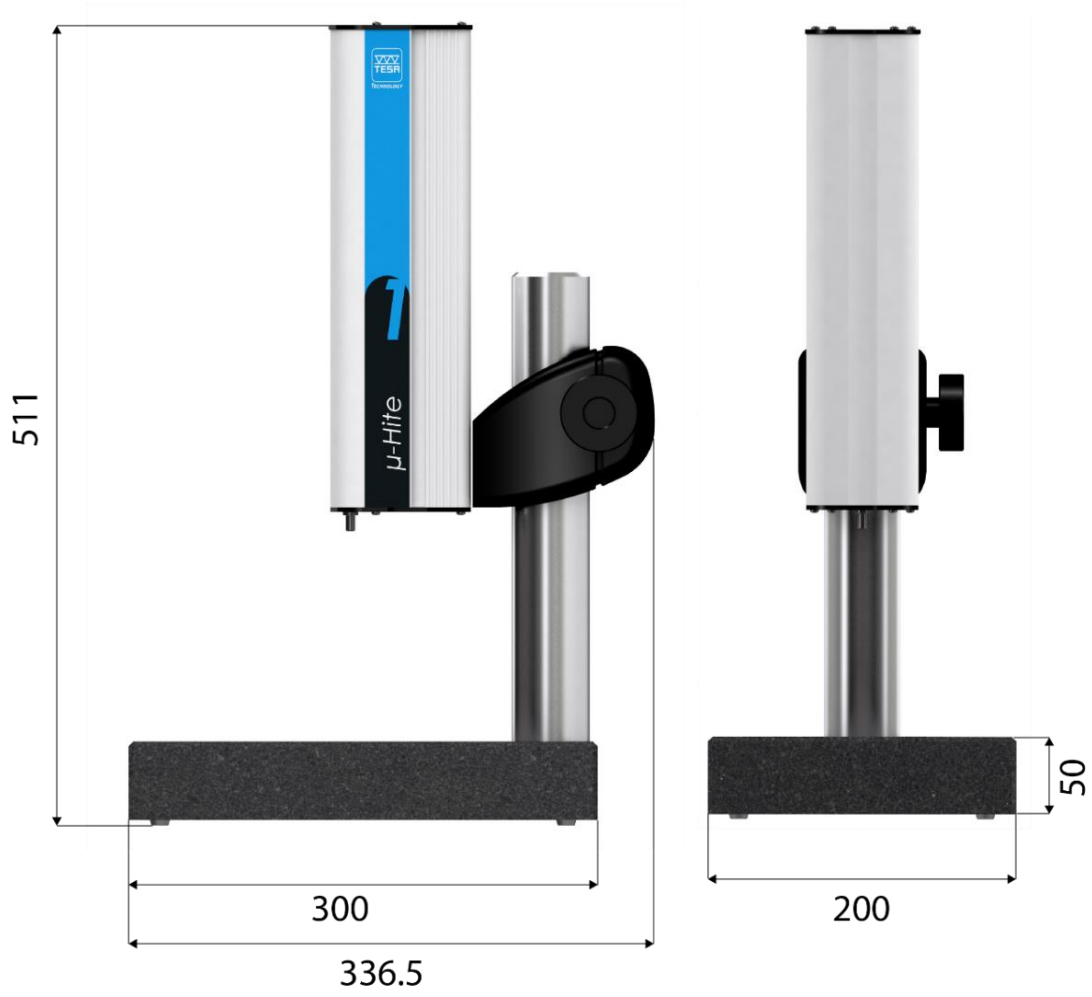

4 DELIVERY CONTENTS

4.1 System components

Each configuration is composed of the following elements:

| Qty | Description | 00730502 | 00730503 |
|-----|---------------------------------------------------------------------------------------------------------------------|----------|----------|
| 1x | Probing head | • | • |
| 1x | Control panel | • | • |
| 1x | Support group <ul style="list-style-type: none"> • Granite table • Pole • Support | - | • |
| 1x | Masterpiece | • | • |
| 1x | Ø3mm eccentric probe | • | • |
| 1x | Probe support + Ø3mm axial probe | • | • |
| 1x | Adaptation box | • | • |
| 1x | Cables: <ul style="list-style-type: none"> Box-panel Box-probing head Power supply | • | • |
| 1x | Power supply | • | • |
| 1x | SCS certificate | • | • |
| 1x | Declaration of conformity | • | • |
| 1x | Quick start manual | • | • |
| 1x | USB key | • | • |
| 1x | Shipment cardboard | • | • |

4.2 Packaging

The elements that constitute the packaging of your measuring station are very important, therefore you should keep them. It is absolutely necessary to use the original packaging when transporting the instrument in order to avoid any unfortunate deterioration which could cause malfunction or complete impossibility to use the instrument.

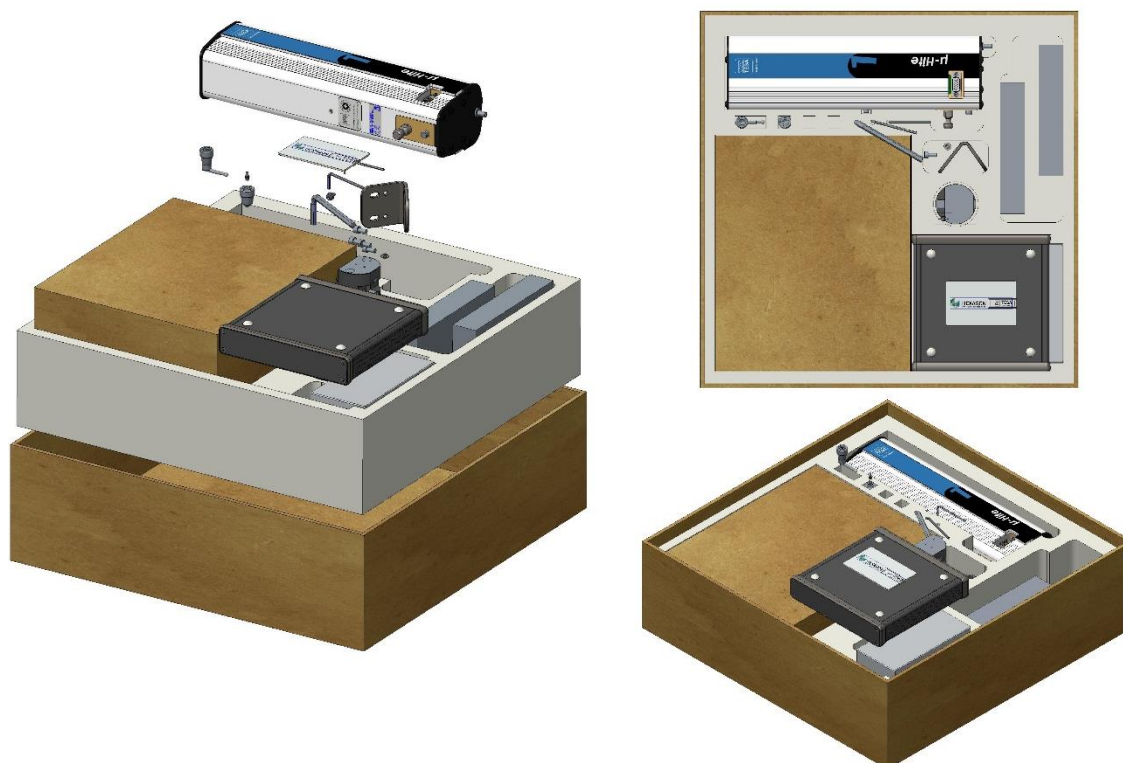

4.3 Calibration certificate

Each **instrument** is provided with an individual calibration certificate. The number of the certificate is the same as the serial number of the instrument, as it is indicated on its label. If the two numbers are not the same, please contact your local reseller.

The documented measuring results of the calibration certificate refer to the condition of the instrument during its final inspection in the factory of TESA. The results obtained and the technical specifications indicated depend on the mentioned environmental factors. If the instrument is not used in ideal conditions, it is very likely that its performances are downgraded.

Reference conditions during calibration

| | |
|----------------------------------------------------------------------|----------------------------------------------------------------------------------------------------------------------------------------------------------------|
| Air conditioning in measurement laboratory | Temperature: (20 ± 0,5) °C Humidity: ≤ 65 % |
| Flatness standard | Granite table, precision class 00 according to DIN 876 part 1 Total guaranteed flatness of 1 µm. |
| Control equipment for determining measurement uncertainty of lengths | Measurement bench The measurement line of the bench is oriented perpendicularly to the reference granite plate. |
| Instrument | Equipped with standard probes: • Eccentric measurements: Ø 5 mm tungsten carbide ball tip. • Axial measurements: standard probe support + Ø 3mm ball tip |
| Master piece | Belonging to the instrument itself, therefore same number on it as indicated on gauge label. |

Measurements

- The reference point for measurements taken on a face of the bench is approximately at the same height as the reference surface of the granite plate.
- The reference point is captured once (probing down) and is valid for all the measurements
- The measurements are carried out with regular nominal distance of 10mm (see calibration certificate). At each level, 3 series of measurements are performed.
- The measurements are carried out with inversion of the probing direction. This means that the measuring faces of the step gauge blocks are probed alternately up and down until the end of the measuring range of the instrument is reached.

Interpreting the results

Interpreting the results according to the standard ISO 13225 your instrument refers to, requires a definition of the following parameters.

B Error of indication of the height gauge for surfaces measured in opposite directions. We talk about bi-directional measurements.

B_{MPE} Upper tolerance of B parameter.

E Error of indication of the height gauge for surfaces measured down. We talk about uni-directional measurement.

E_{MPE} Upper tolerance of E parameter.

R Repeatability error (2σ).

R_{MPE} Upper tolerance of R parameter.

The maximum permissible error is indicated as follows (A, B, C and D are constants, L corresponds to the measured length in meters).

$$B_{MPE} = A + B \times L$$

$$E_{MPE} = C + D \times L$$

Starting from the zero-reference point, with its height position corresponding approximately to the reference surface of the granite plate, no error (measured value – nominal value) is above the admissible limits. All measuring results are therefore in the violet zone.

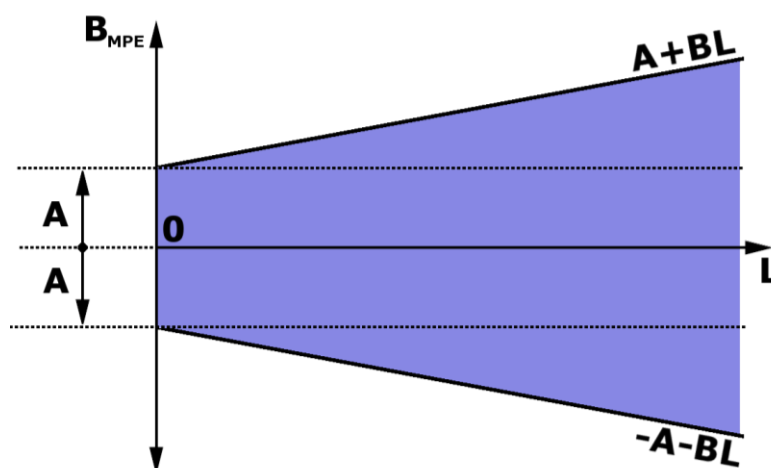

The visualisation of the schema of E_{MPE} is identical to the one above, except that parameters A and B are replaced by C and D. It is also possible that the technical specifications of certain products indicate $A = C$ and $B = D$.



The μ -HITE is an instrument with a “fixed zero”. This means that in order to have measuring results in accordance with the specifications indicated by the maximum permissible error, the reference used in a measurement sequence has to be measured on the granite table generally used for most applications.

5 INSTALLATION, SECURITY & MAINTENANCE

| | |
|--------------------------------------------------|------------------------------------------------------------------------------------------------------------------------------------------------------------------------------------------------------------------------------------------------------------------------------------------------------------------------------------------------------------------------------------------------------------------------------------------------------------------------------------------------------------------------------------------------------------------------------------------------------------------------------------------------------------------------------------------------------------------------------------------------------------------------------------------------|
| <p>5.1 Location</p> | <p>The instrument has to be installed in a location satisfying the general required conditions, but also the specific and very precise conditions regarding the environment, power supply, etc. It is essential to be able to identify important factors and to correctly prepare the zone the instrument is installed and used in.</p> |
| <p>5.2 Place of use</p> | <p>In order to use the instrument correctly, the following precautions have to be taken into account:</p> <ul style="list-style-type: none"> • Avoid placing the instrument close to a window, door, cooling, or heating system. • Avoid causing recurrent temperature variations due to direct exposure of the instrument to the sun. • Avoid installing it close to other machines that could induce large electromagnetic fields. |
| <p>5.3 Lighting</p> | <p>Use indirect or fluorescent light. Avoid direct exposure to the sun or any other strong light.</p> |
| <p>5.4 Measuring surface</p> | <p>Choose a surface free of any vibrations that could lead to measurement or reading errors despite the stability of the mechanical and electronic components.</p> <p>Make sure that the surface can carry the weight of the machine and the workpiece to be measured. Ideally, the surface should not have any splits or joints.</p> <p>It is recommended to use a measuring surface that is big enough to enable smooth and easy movements of the instrument around the workpiece to be measured if the latter cannot be displaced manually.</p> |
| <p>5.5 Cleanliness</p> | <p>Make sure that the floor surface is clean, so that there is no dust, condensation or metal filings. The supports and scales have to be perfectly clean without any oily particles on it.</p> |
| <p>5.6 Vibrations</p> | <p>Floors of companies are constantly at risk of vibration due to different reasons: CNC and other machines, transportation vehicles and any other source of vibrations. These vibrations can directly influence the metrological performances of the machine.</p> |
| <p>5.7 Electric power supply</p> | <p>Stability When the instrument is powered electrically via the cable connected to the network, make sure that the electric power supply of the machine is as stable as possible, as it could otherwise deteriorate the system. If the electric network the machine is connected to does not provide sufficient stability, it is highly recommended to use an additional device to avoid any damage. These devices can be found locally.</p> <p>Power cable Do not use any other power cable than the one provided with the instrument.</p> <p>Transformer Do not use any other transformer than the one provided with the instrument.</p> <p>Voltage Do not use the instrument with any other voltage than the one indicated in this manual.</p> |
| <p>5.8 Maintenance of the Masterpiece</p> | <p>To maintain in good condition the surfaces of the gauge blocks constituting the Masterpiece, it is recommended to keep these surfaces greased when the gauge is not in use.</p> <ul style="list-style-type: none"> • Before each use, the measuring surfaces must be thoroughly degreased and cleaned. • After use, protect measuring surfaces with a thin layer of grease. |
| <p>5.9 Final use</p> | <p>The instrument is to be used for measurements only.</p> |
| <p>5.10 Storage</p> | <p>It is important to respect the storage temperature limit indicated in the specifications of the instrument.</p> |

5.11 Cleaning | Only use a dry, lint-free cloth for cleaning the instrument. Do not use aggressive solvents.

5.12 Opening elements | Never try to open the control panel or the height gauge. Access is only allowed to qualified and authorised personnel.



If a person not authorised opens one of these elements, the warranty period automatically ends.

5.13 Recycling | Do not dispose of this product with municipal waste.



This product has been designed to allow proper reuse and recycling of parts. The crossed-out wastebin symbol indicates that the product (electrical, electronic and/or containing a mercury battery equipment) must not be disposed of with municipal waste. Refer to local regulations for disposal of electronic products.

6 INSTALLATION

6.1 Packaging

Each μ -HITE instrument is delivered in packaging developed to protect it from shocks and corrosion.



Only transport the height gauge in this packaging. Any other transport using unofficial packaging is not recommended and will not be covered by TESA in case of dispute.

6.2 Unpacking & installation

1. Bring the box as close as possible to the installation area.



2. Remove the upper inside box (retrofit kit) and put it aside temporarily. It should not hinder the granite table set up.



3. Open the lowest inside box without removing it from the global box.



4. Remove the granite table, the pole and the support from the box.



5. Place the system in the use zone.



6. Open the other box (retrofit kit)

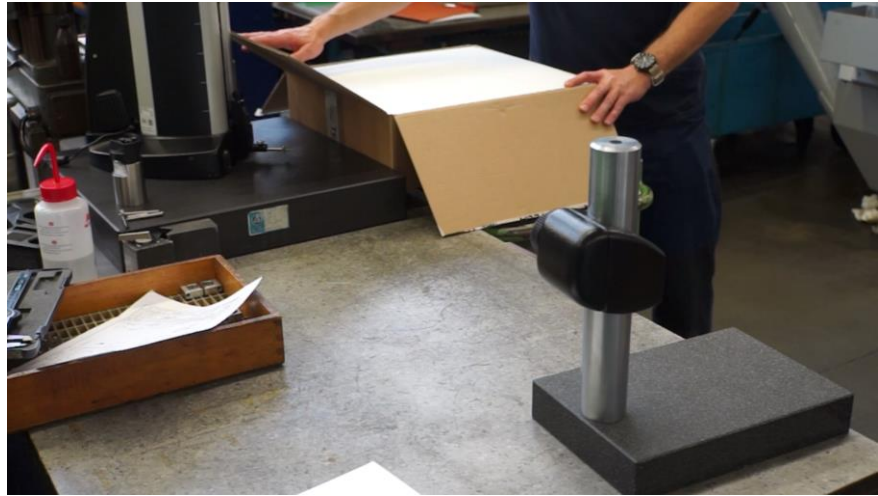

7. Remove carefully the probing head from its plastic bag and place it on the table.



8. Remove the adaptation box.



9. Remove the cables from the box.

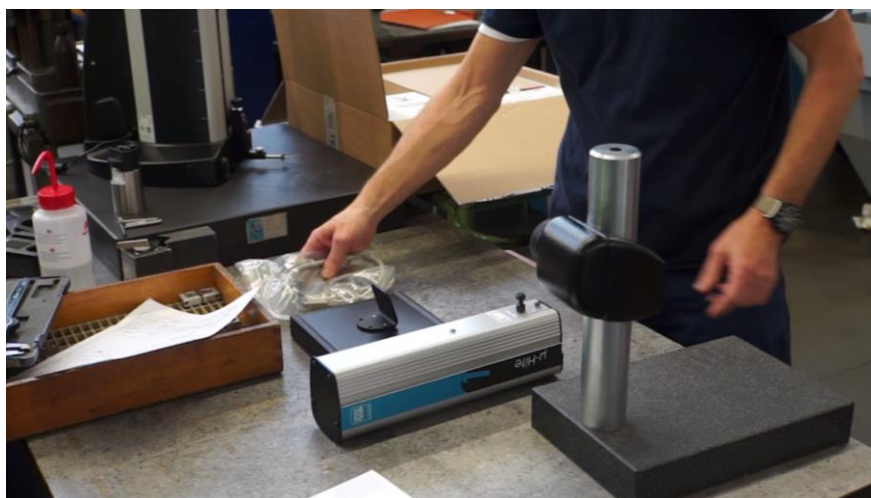

10. Remove the masterpiece from the box.



11. Remove the probes as well as the panel fixing piece from the box.



12. Remove the control panel from the box.

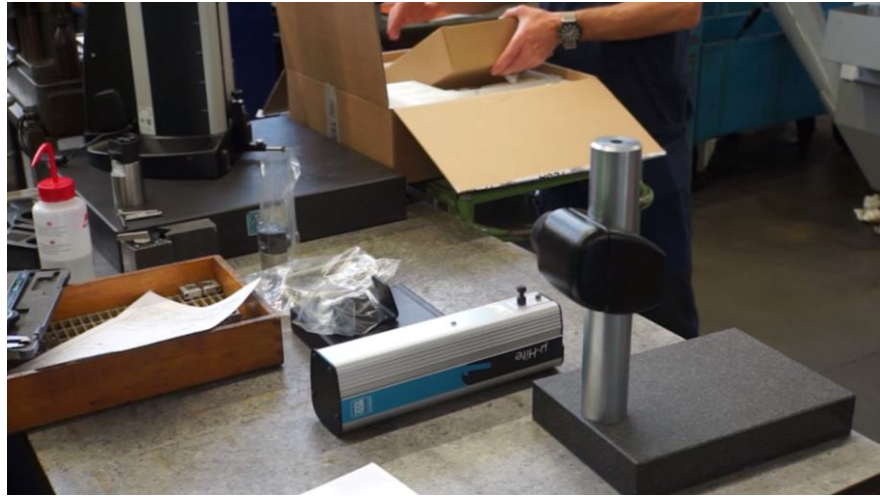

13. Remove the power supply from the box.



14. Unscrew the screw at the rear of the probing head. It is used to hold the system in place during transportation.



15. Mount the probing head on the support.



16. Fix the probing head tightening the screw on the lowest surface of the support.



17. Remove the panel from its box.



18. Position the fixation piece at the rear of the panel.



19. Mount the piece with the two screws.



20. Position the panel above the adaptation box.



21. Fix the control panel on the adaptation box with two screws.



22. Mount the « panel-box » cable at the rear of the panel.



23. Connect the cable at the rear of the box.



24. Connect the « box-probing head » cable at the rear of the box.

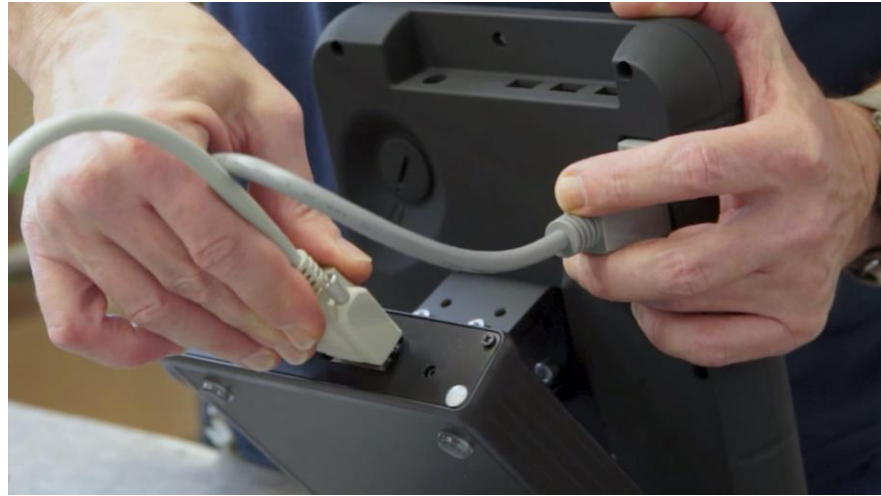

Any cable connections have to be established while the instrument is turned off. Make sure that the instrument is turned off each time the « panel-box » and/or « box-probing head » cables are disconnected.

25. Connect the power supply cable at the rear of the box.



26. Connect the other cable extremity to the probing head.



27. Pull down the axis to access easily its extremity.



28. Mount the probe on the axis and tighten it with the screw on its side.



29. Clean the granite table.



30. Remove the masterpiece from its plastic bag and clean its base.



31. Remove the screen protection.



6.3 Printer installation

1. If necessary, remove the panel from the adaptation box by unscrewing the 4 screws at the rear of the panel.



2. Hold the printer in position and screw the same 4 screws.



3. As soon as the printer is correctly fixed, it is necessary to connect it to the panel via the USB cable provided with.



4. Connect the power jack as well.



Your printer is now ready to be used by activating the process in the system settings.

6.4 Pedal installation

You can use your measuring station together with two different types of switches: operable with the hand or the foot.



Foot pedal
04768001



Hand pedal
04768000

These two pedals have a jack type connector. To use them you must connect them at the rear of the adaptation box.



7 CONTROL PANEL

7.1 General description

The control panel of your measuring station has been developed to enable an ideal navigation through its software and an intuitive use.



Its keyboard is separated in four zones of keys that are easily distinguishable by the functions accessible through them.

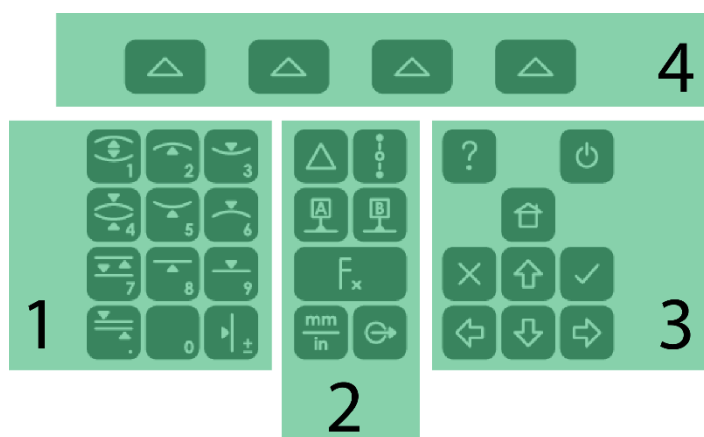

| N° | Description |
|----|--------------------------------------------------------------------------------------------------------------------------------------------------------------------------------------------------------------------------------------------------------------|
| 1 | Measurement zone + numerical keyboard <ul style="list-style-type: none"> • Start a measurement (on MH+M) • Define the type of measurement: axis or bore (on MH) • Insert a numerical value |
| 2 | Calculation zone <ul style="list-style-type: none"> • Calculate differences or averages • Manage references • Change measuring units • Manage transmission of data • Access to secondary functions |
| 3 | Software navigation <ul style="list-style-type: none"> • Turn the instrument on or off • Access to online help • Validate or cancel actions • Go back to main menu • Displace selection of options |
| 4 | Validation of context-based options |

7.2 Touchscreen

To offer you more comfort, most of the functions available via the keyboard of the control panel are also available via the touchscreen.

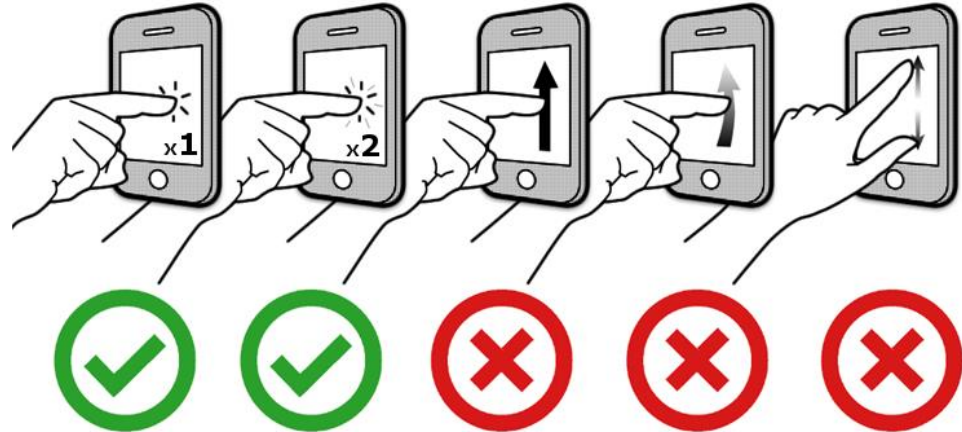

The control panel is touchscreen only technology. Swiping the screen is not possible.

















7.3 Measurement zone

There are two different types of actions possible using the keys of this zone:

- Numerical keyboard
- Measurement function

The numerical keyboard can be used at any moment, when the user has to enter a value manually. The user has the possibility to enter it via the control panel keyboard or on the touchscreen.







| Definition of the keys | |
|------------------------|-----------------------------------------------------------------------------------------------------------------------------------------------|
| | <ul style="list-style-type: none"> Start automatic bore measurement Insert value 1 |
| | <ul style="list-style-type: none"> Start automatic measurement of maximum internal culmination point Insert value 2 |
| | <ul style="list-style-type: none"> Start automatic measurement of minimum internal culmination point Insert value 3 |
| | <ul style="list-style-type: none"> Start automatic axis measurement Insert value 4 |
| | <ul style="list-style-type: none"> Start automatic measurement of minimum external culmination point Insert value 5 |
| | <ul style="list-style-type: none"> Start automatic measurement of maximum external culmination point Insert value 6 |
| | <ul style="list-style-type: none"> Start automatic groove measurement Insert value 7 |
| | <ul style="list-style-type: none"> Start automatic measurement of upper point |

| | | |
|-----------------------------------------------------------------------------------|-----------------------------------------------------------------------------------|-------------------------------------------------------------------------------------------------------------------------------------------------------------------------------------------------------------------------------------------------------------------|
|  |  |  Insert value 8 |
|  |  |  Start automatic measurement of lower point  Insert value 9 |
|  |  |  Start automatic measurement of a rib  Insert a point or comma |
|  | |  Insert value 0 |
|  | |  Save the position of the measuring probe in the memory  Change the sign of the active value |

7.4 Calculation zone

This zone features different functions:









- Calculation function
- Managing references
- Access to secondary menus
- Transmission of data
- Change of unit

| Definition of keys | |
|-------------------------------------------------------------------------------------|-------------------------------------------------------------------------------------------------------------------------------------------------------------------------------------------------------------------------------------------------------------------------------------------------------------------------------------------------------------------------------|
|  | <ul style="list-style-type: none"> • Calculation of the difference between two selected values • Calculation of the difference between the two last measurements (if two blocks are not selected) • Creation of a measurement block • Calculation of the difference between points and creation of a measurement block (2D mode) |
|  | <ul style="list-style-type: none"> • Calculation of the midpoint between two selected values • Calculation of the midpoint between the two last measurements (if two blocks are not selected) • Creation of a measurement block • Creation of a measurement block corresponding to the midpoint between 2 selected blocks (2D mode) |
|  | <ul style="list-style-type: none"> • Definition of reference A • Recall reference A |
|  | <ul style="list-style-type: none"> • Definition of reference B • Recall reference B |
|  | Access to secondary functions |
|  | Change of unit |
|  | <ul style="list-style-type: none"> • Manually send measurement values to the activated devices • Screenshot saved in USB key |

7.5 Software navigation

The keys in this zone allow the user to move the selected zone to the requested place and to navigate through the software.

| Definition of keys | |
|-------------------------------------------------------------------------------------|---------------------------------------------------------------------------------------|
|  | Activate the help menu for the active page |
| | <ul style="list-style-type: none"> • Turning on and off the instrument |

| | |
|-----------------------------------------------------------------------------------|----------------------------------------------------------------------------------------------------------------------------------------------------------------------------------------|
|  | <ul style="list-style-type: none"> If the instrument is on standby, the backlight of this button turns blue. It is then the only backlit button on the entire keyboard. |
|  | Return to main menu |
|  | Move the selection to the left |
|  | Move the selection up |
|  | Move the selection to the right |
|  | Move the selection down |
|  | Cancel |
|  | Validate |

7.6 Context-based actions

At any moment of the software use, context-based actions will be displayed in the black bar positioned at the bottom of the screen.

These options can be selected either directly touching the screen or pressing the key  that corresponds to the respective action.

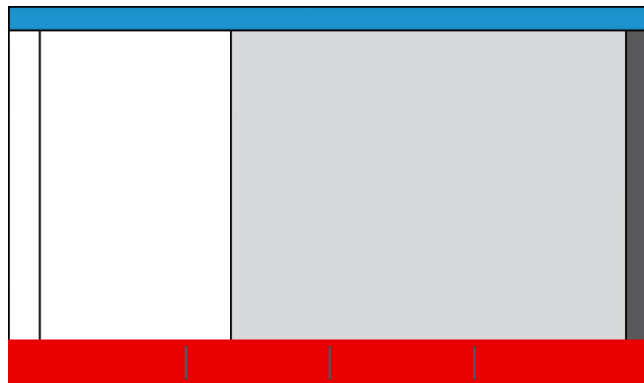

Location of additional options displayed according to the active page

A chapter which summarises the context-based actions is available at the end of this document.



8 MEASUREMENT INTERFACE

8.1 Status bar

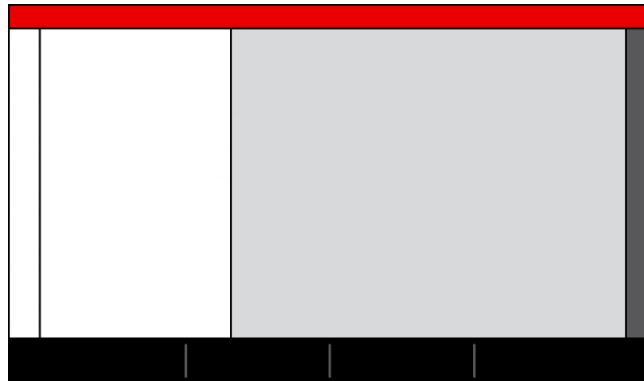
The status bar on top of the screen gives you access to the state of the system at any time.



This bar provides the following information:

| | |
|-----------------------------------------------------------------------------------|-----------------------------------------|
| Calculator | The title of the active page/mode |
|  | The battery level and level of charging |
| 1:49:35 PM | Time |
|  | The active devices when sending data |
| mm deg | The active units |

8.2 Main zone

All values and measurement results will be calculated and displayed in the main zone corresponding to all red rectangles in the picture below.

Information and help regarding the different steps of a process will also be displayed in this zone in order to help the user with the measurement.

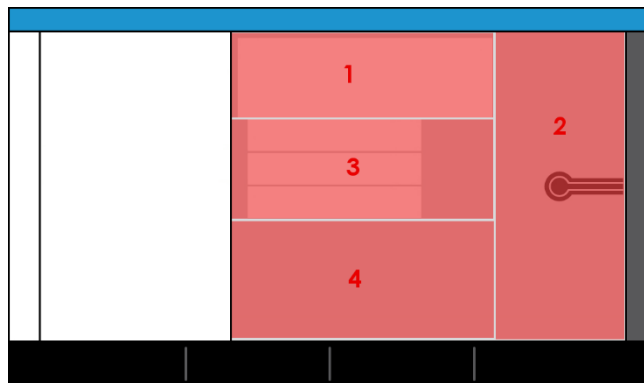



| N° | Description |
|----|----------------------------------------------------------------------------------------------------------------------------------------------------------------------------|
| 1 | <ul style="list-style-type: none"> • Display of the main measurement value. • Information of number of probe hits required to finish a measurement |
| 2 | Information/help image regarding the active mode and the step of the measurement process |
| 3 | <ul style="list-style-type: none"> • Secondary results • Values used for the active process (example: gage block's size for angle measurement) |
| 4 | Information/help text (linked to the action defined in zone No. 2) |

8.3 Trigger force

The zone dedicated to the measuring force is displayed on the right of the screen.



When capturing a point, this bar will change its colour according to the force applied on the probe and thus measuring carriage.

| Colour | Description |
|------------------------------------------------------------------------------------|--------------------------------------------------------------------------------------------------------------------|
|  | The pressure applied on the probe is perfect. The measurement is correct. |
|  | The pressure applied on the probe is not sufficient to trigger the measurement. |
|  | The pressure applied on the probe is too high. The measurement would not be correct and is therefore not possible. |

8.4 Context-based actions bar



In this bar, additional actions to the possibilities offered by the keyboard of the control panel are displayed. These options are directly linked to the active page of the software.

8.5 Measurements list

After each measurement, the main result is, in general, automatically saved in this zone within a measurement block containing several pieces of information.

 **However, in certain modes, after a measurement, the user has to select from a list of results which value is relevant enough to be saved in the measurement memory/history.**

This zone therefore serves as a memory of measurements in order to later save them. This will then allow to restart the measurement sequence on another similar workpiece.



The measurement blocks are defined by:

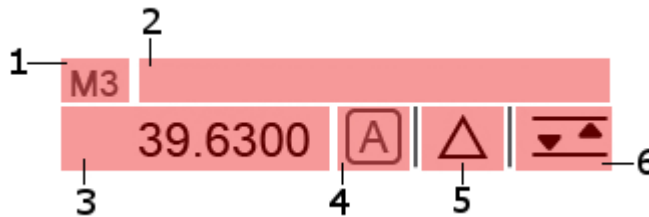

| N° | Description |
|----|--------------------------------------------|
| 1 | Number of the measurement block |
| 2 | Editable name of the measurement block |
| 3 | Measurement result |
| 4 | Reference linked to the measurement result |
| 5 | Feature of the measured element |
| 6 | Measurement action or measured element |

Our example above shows that the third measurement of the sequence has been carried out in datum A on a groove with a dimension of 39.63 mm.

The maximum number of measurement blocks (considering all different measurements lists as ST1, ST2, ...) is approximately 2000. Since each block does not have the same amount of information, it is possible that this upper limit varies depending on the measurements stored in the histories.

An alert message is displayed when the maximum limit is reached.

8.6 Location



If the number of displayed blocks in the history exceeds the size of the screen, this tool allows to:

- navigate through the measurement programme via the keys and .

- to see the instant location in the programme at any moment via a .

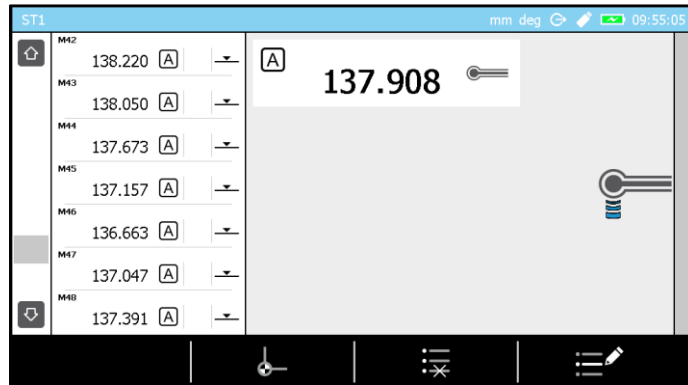

When recalling a measurement sequence, a  will give information about the step of the measurement or the measurement block which the software is in and has to be carried out.

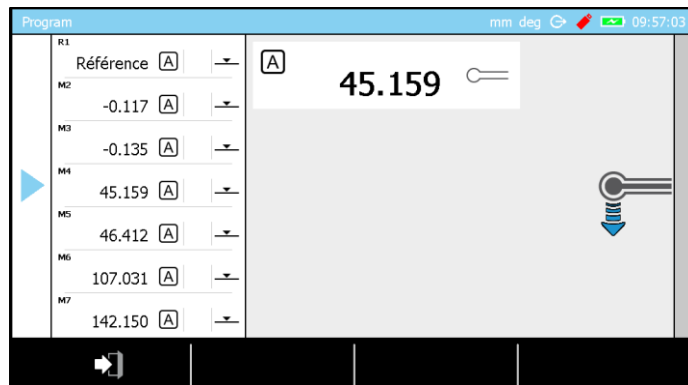

9 SYSTEM OPTIONS

9.1 Access

The system options are accessible at any moment from the main menu by pressing the key

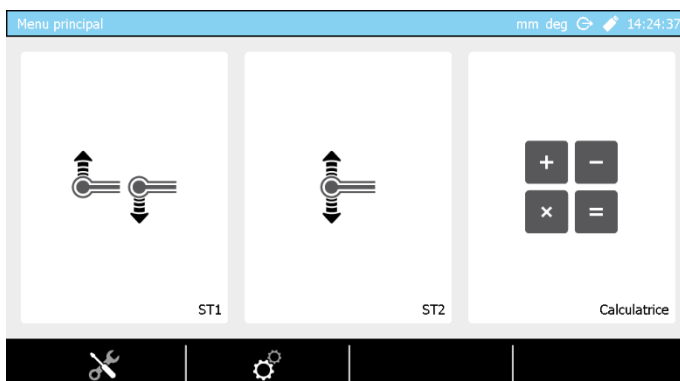

It is possible to go back to main menu from any page of the software by pressing the key .



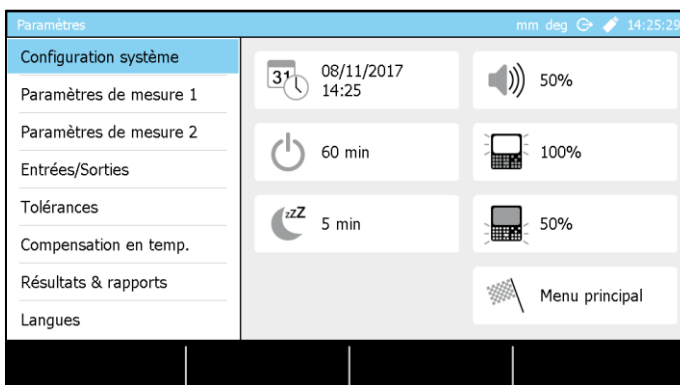



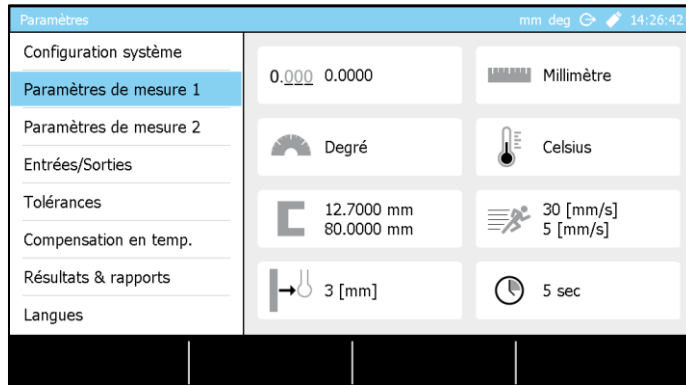

9.2 System configuration



| Definition of options | |
|-----------------------|------------------------------------------------------------------------------------------------------------------------------------------------------------------------------------------------------------------------------------------------------------------------------|
| | Definition of time and date |
| | Time defined before complete shutdown of the system (if the system is not used during this period). If the gauge is connected to the electric power network, this option is not taken into account and the height gauge will not shut down automatically. |
| | Time defined before standby mode of the system (if the system is not used during this period). |
| | Defines the activated mode directly after instrument's initialisation <ul style="list-style-type: none"> • ST1: direct access to ST1 mode • ST2: direct access to ST2 mode • Main menu: direct access to the main menu |
| | Managing the loudspeaker |
| | Managing the screen brightness |
| | Managing the keyboard's backlight |

9.3 Measurement parameters 1





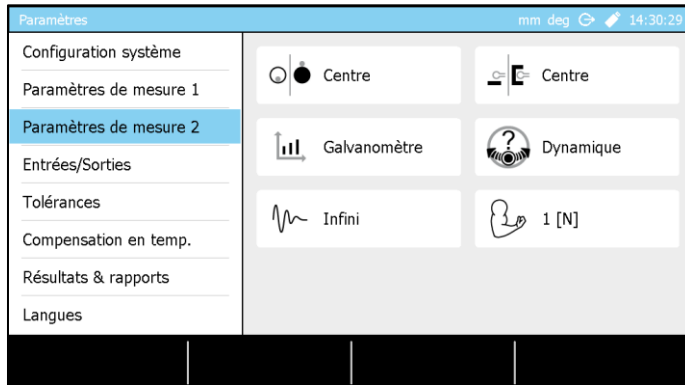

| Definition of options | |
|-------------------------------------------------------------------------------------|---------------------------------------------------------------------------------------------------------------------------------------------------------------------------------------------------------------------------------------------------------------------------------------------------------------------------------------------------------------------------------------------------------------------------------------------------------------------------------------------------------------------------------|
|  | <p>Definition of the resolution</p> <ul style="list-style-type: none"> • Metric: 0.000, 0.0000 • Imperial: .0000, .00000 |
|  | <p>Managing the unit</p> <ul style="list-style-type: none"> • Metric • Imperial |
|  | <p>Definition of the angle unit</p> <ul style="list-style-type: none"> • DD:MM:SS • Degree • Radian |
|  | <p>Definition of the temperature unit</p> <ul style="list-style-type: none"> • Celsius • Fahrenheit |
|  | <ul style="list-style-type: none"> • Size of the master piece • Height of the automatic positioning of the probe when starting the probe calibration's process |
|  | <p>Retract distance after probe hit</p> |
|  | <p>Speed</p> <ul style="list-style-type: none"> • Fast displacement: 10, 20, 30, 40 mm/s • probing: 5, 10 mm/s <div style="background-color: #f0e6e6; padding: 5px; margin-top: 10px;">  <p>The stated technical specifications for a μ-HITE have been calculated with a probing speed of 5mm/s. Using any other probing speed can lead to variations in the gauge accuracy.</p> </div> |
|  | <p>Waiting time when running a measuring sequence:</p> <ul style="list-style-type: none"> • before any displacement toward a new measurement zone • before any measurement <p>If the distance between the current and next zone is small, the software will start the timer only once.</p> |

9.4 Measurement parameters 2

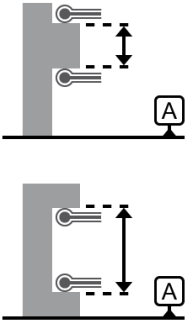

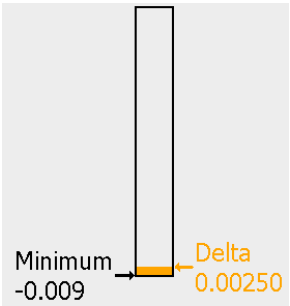
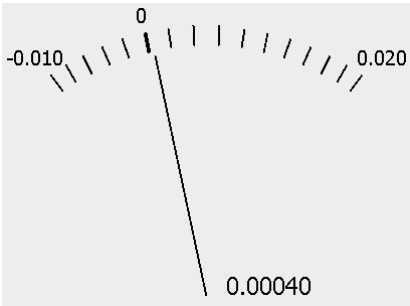
| Definition of the options | |
|---------------------------|---------------------------------------------------------------------------------------------------------------------------------------------------------------------------------------------------------------------------------------------------------------------------------------------------------------------------------------------------------------------------------------------------------------------------------------------------------------------------------------------|
| | <p>Trigger force</p> <ul style="list-style-type: none"> • 1 ± 0.1 N • 0.63 ± 0.1 N |
| | <p>Stabilisation time before measurement</p> <ul style="list-style-type: none"> • 1s • infinite |
| | <p>Definition of a culmination point detection process</p> <ul style="list-style-type: none"> • Static <ol style="list-style-type: none"> Positioning the probe at the culmination point by moving the workpiece and: Height measurement of one (or two) culmination point(s) without moving the workpiece by simple up/down probing. • Dynamic Culmination point (height) calculated on the fly by moving the workpiece |
| | <p>Setting the results main value when measuring a groove / rib.</p> <ul style="list-style-type: none"> • Midpoint of an element The main value is the midpoint of the element <div style="text-align: center;"> </div> |

| | |
|-------------------------------------------------------------------------------------|----------------------------------------------------------------------------------------------------------------------------------------------------------------------------------------------------------------------------------------------------------------------------------------------------------------------------------------------------------------------------------------------------------------------------------------------------------------------------------------------------------------------------------------------------------------------------------------------------------------------------------------------------------------------------------------------------------------------------------------------------------------------------------------------------------------------------------------------------------------------------------------------------------------------------------------------------------------------------------------------------------|
| | <ul style="list-style-type: none"> Size/width of an element The main value is the size/width of the element (height difference between high and low point)  Midpoint & Size/width The main value is the midpoint of the element. However, two blocks will be automatically generated anyway at the end of the measurements list. These blocks store the value of the midpoint as well as the size/width of the element to be measured. Size/width & Midpoint The main value is the size/width of the element. However, two blocks will be automatically generated anyway at the end of the measurements list. These blocks store the value of the midpoint as well as the size/width of the element to be measured. |
|  | <p>Selection of the type of graph helping to detect the culmination point. This selection defines the graphic type that will be displayed on standard. Nevertheless, it is also possible to modify the type in the measurement mode, when the graphic is being displayed.</p> <ul style="list-style-type: none"> Bar graph Galvanometer <div style="display: flex; justify-content: space-around;"> <div data-bbox="679 1294 970 1630">  <p style="text-align: center;">Bar graph</p> </div> <div data-bbox="1054 1294 1465 1630">  <p style="text-align: center;">Galvanometer</p> </div> </div> |
|  | <p>Setting the result defined as main value when measuring a bore or axis.</p> <ul style="list-style-type: none"> Midpoint The main value is the height of the centre of the element |

- Diameter**
 The main value is the diameter of the element

- Midpoint & Diameter**
 The main value is the midpoint of the element. However, two blocks will be automatically generated anyway at the end of the measurements list. These blocks store the value of the midpoint as well as the diameter of the element to be measured.
- Diameter & Midpoint**
 The main value is the diameter of the element. However, two blocks will be automatically generated anyway at the end of the measurements list. These blocks store the value of the midpoint as well as the diameter of the element to be measured.

Centre
Diameter

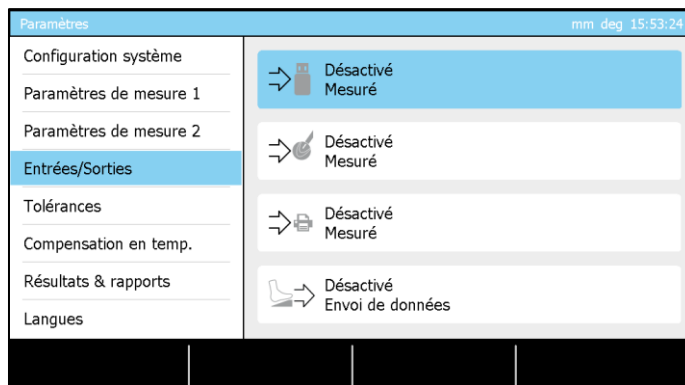

9.5 Input/outputs









All data output (send to USB, ...) management can be done according to:

- Automatic**

Each measured value (which is stored in measurement list) is automatically sent live to the activated device(s)

- Manual, last value**
 The last value of the measurements list is sent to the activated device(s) if the user presses the  button from the panel keyboard
- Manual, all values**
 All values of the measurements list are sent to the activated device(s) if the user presses the  button from the panel keyboard
- Deactivated**
 No value is sent

| Options | |
|-------------------------------------------------------------------------------------|----------------------------------------------------------------------------------------------------------------------------------------------------------------------------------------------------------------------------------------------------------------------------------------------------------------------------------------------------------------------------------------------------------------------------------------------------------------------------------------------------------------------------------------------------------------------------------------------------------------------------------------------------------------------------------------------------------------------------------------------------------------------|
|  | Sending data to USB key <div style="border: 1px solid black; background-color: #f8d7da; padding: 5px; display: inline-block;">  The USB key used has to be formatted as FAT32. For further details, please contact your local representative. </div> |
|  | Sending data through TLC connector |
|  | Sending data to printer |
|  | This option is useful when you want to use the measurement station along with a pedal. The pedal is a quick and easy mean to use the hands for the management of the pieces to be measured, when a batch has to be controlled for instance. This option could be set from two manners : <ul style="list-style-type: none"> • Sending data The action is the same as the  from the panel keyboard • Last measurement action Allow to run as many times as wanted the last measurement action that has been performed. |

9.6 Tolerances

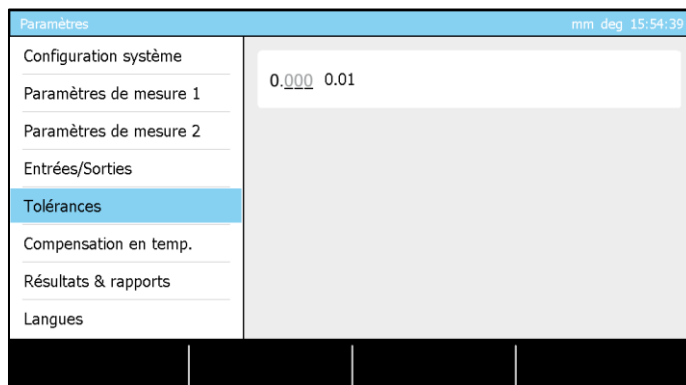

Once a sequence has been created, it is often necessary to insert tolerances for each measured dimension. To allow the user to be faster, the nominal value for each of the program block is calculated from the corresponding measured value. This calculation is made from the help of this option (rate) which is the mean for the software to clarify the way the values have to be rounded. Note it is always possible to edit an automatically calculated nominal value later.

Examples of nominal values calculation:

| Measured value | Rate | Automatically calculated nominal value |
|----------------|-------|----------------------------------------|
| 1.2345 | 0.01 | 1.23 |
| 1.2345 | 0.02 | 1.24 |
| 1.2345 | 0.001 | 1.235 |



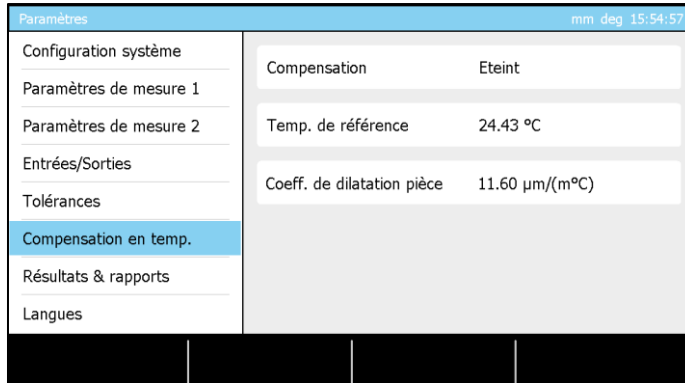

9.7 Temperature

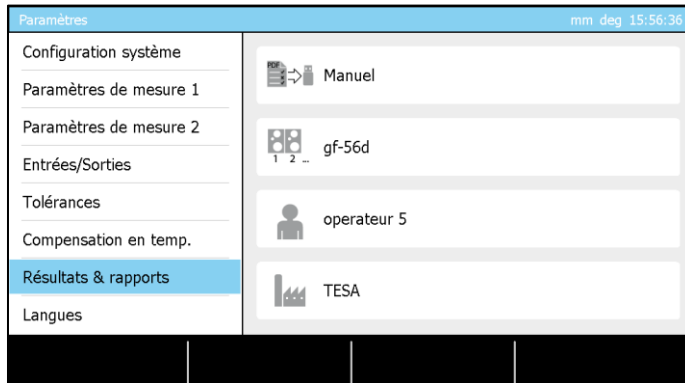

The gage integrates a temperature compensation system that can be enabled or disabled when desired. When active, a calculation takes into account the reference temperature representing the environmental temperature in order to modify the measured values taking also into consideration the thermal expansion coefficient selected.

9.8 Results & reports



| Options | |
|-------------------------------------------------------------------------------------|-------------------------------------------------------------------------------------------------------------------------------------------------------------------------------------------------------------------------------------------------------------------------------------------------|
|  | Activate or deactivate the creation of reports in *.pdf format on the USB stick. The creation can be: <ul style="list-style-type: none"> • Automatic at the end of the execution of a measurement programme • Manual by choosing the corresponding context-based action |
|  | Batch name to be displayed in the header of the *.pdf measurement report |
|  | Operator name to be displayed in the header of the *.pdf measurement report |
|  | Company name to be displayed in the header of the *.pdf measurement report |

9.9 Languages



You can easily change the language by selecting your desired option. The language of the control panel will immediately change.

9.10 Customised language

Additionally, to the basic languages it is possible to personalise the language of your height gauge. To do so, please contact the TESA team or your local reseller.

10 INITIALISATION

10.1 Concept

In general, the initialisation process is the first step after turning on the instrument.

| N° | Description |
|----|--------------------|
| 1 | Steel frame |
| 2 | Glass scale |
| 3 | Probe axis |
| 4 | Probe |
| 5 | Granite table |
| 6 | Pole |
| 7 | Reference mark |
| 8 | Encoder |
| 9 | Probe head support |

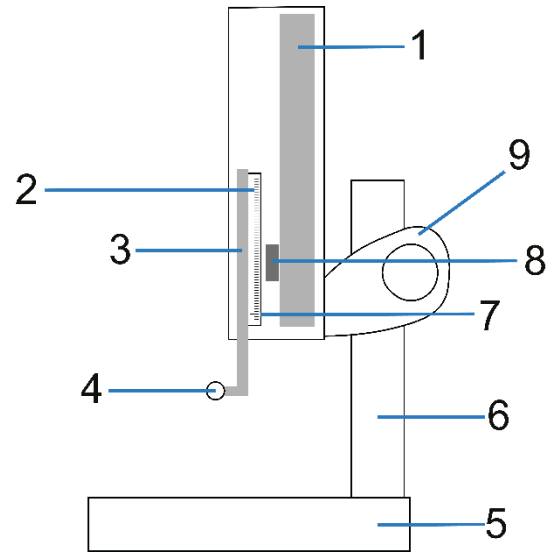

The probe support and the probe (4) are directly linked to a small system (probe axis) on which the glass scale (2) is fixed. At any time after the gage is switched on, the non-contact encoder (8) reads the incremental divisions on the glass scale (2). One of these divisions is considered as the reference from which the gauge will always calculate the probe displacement. This mark is called the reference mark (7).

The initialisation process therefore consists in moving the sensor in front of the reference mark. This is the reason why, when performing a gauge initialisation, the probe moves first up.

10.2 Process

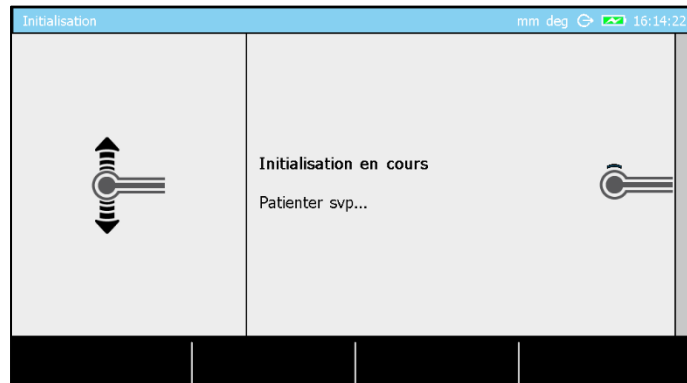

Once the μ -HITE is turned on and the software is loaded, the initialisation page is accessed and the gauge automatically starts to search the reference mark. It will first move down approximately 4-5 cm. If the reference mark is not found or the lower limit of the instrument is reached, the sensor will move up. The process is finished once the sensor has detected the reference mark on the glass scale.

11 DETERMINATION OF THE PROBE CONSTANT

11.1 Masterpiece

Each gauge is provided with a standard, also called master piece.



It is necessary to use this accessory with most of the measurement modes integrated in the **μ-HITE**.



Calibration with groove of the master piece



Calibration with rib of the master piece



The master piece has to be as clean as possible when it is used, as it is, to a large extent, the measurement of this tool that will determine the accuracy of the results obtained later.

In order to allow the user to carry out measurements without any time-consuming calculations, the constant of the probing system is determined on the master piece, whose dimension is known. By combining 3 standards of which it is constituted, it represents an internal or external dimension of 12.7 mm / .50000 in.



It is important to only use the master piece provided with the instrument. TESA do not guarantee correct functioning of the instrument if it is used with another master piece than the one provided by default.



The final inspection and the certificate of the instrument both refer to this master piece.

11.2 Maintenance of the Masterpiece

To maintain in good condition the surfaces of the gauge blocks constituting the Masterpiece, it is recommended to keep these surfaces greased when the masterpiece is not in use.

- Before each use, the measurement surfaces of the masterpiece must be thoroughly degreased with a paper or cloth dampened with a non-aggressive solvent.
- Continue cleaning with a lint-free or microfiber cloth until grease traces or other dirt is completely removed.
- After each use, the surfaces of the gauge blocks constituting the Masterpiece shall be protected by a thin layer of grease.

11.3 Concept

When measuring elements that require probing in two directions, it is necessary to take into account the probe constant.

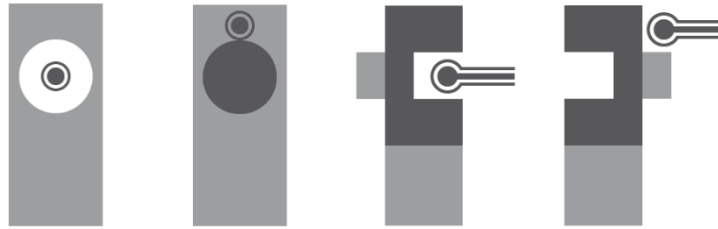

Elements that require two probe hits: bore, axis, groove, rib

The probe constant is a permanent correction factor. It is calculated by the control panel after master piece measurements, then saved and automatically taken into account during the next measurements.

The probe constant considers and compensates the main influencing factors such as:

- Diameter of the used ball or disc probe
- Elastic deformation of the probe and its support due to the measuring force
- Hysteresis error of the measurement system



Each time the measurement conditions change, the probe constant has to be determined again. The main causes of modification are:

- Turning off the instrument
- Probe change
- Probe position modification
- Measurement mode change

In case the measurement sequence does not require the use of the probe constant, all values are offset from the radius of the probe. This is the $ST1$ mode.

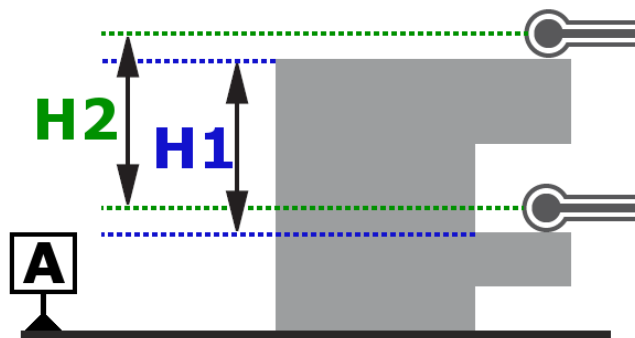

$$H1 = H2$$

If probing in two directions is accepted in the same measurement sequence, this is the case in particular thanks to the compensation of the ball-tip radius in the probing direction. This is the $ST2$ mode.

Without compensation of the ball-tip, the displayed value in the case below would be H2, although the required value is H1.

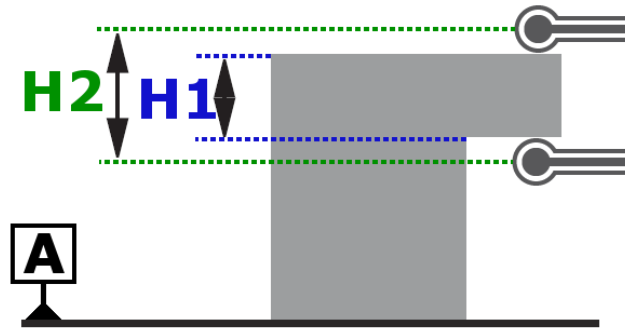

$H2 \neq H1$

Schema representing the compensation of the ball-tip:

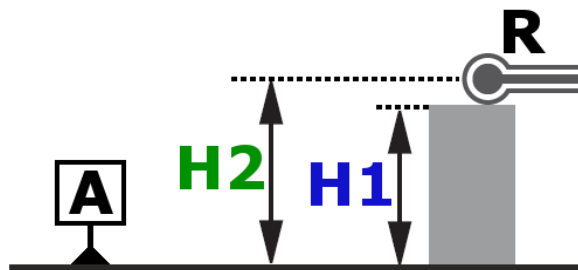

In order to determine the right point, each height H1 is recalculated according to H2 (which corresponds to the centre of the ball-tip) and the radius R of the insert (defined when detecting the probe constant).

11.4 Procedure

There are several processes to determine the probe constant. The TESA master piece design has been thought to minimise the determination time and avoid any errors that could occur when moving the master piece during a sequence.

The calibration procedure of the probe (or determination of the probe constant) requires at least two probe contacts for each measurement point.



The difference between the two values obtained for each point cannot exceed a maximum value that depends on the selected resolution.

If it is higher than this limit value, the difference is displayed. The user then has the choice to accept it and bypass the process with  button, or to restart the process for a new measurement.

If the user accepts the result, the number of digits after the comma will be reduced to be in line with the probe constant.

11.5 Steps

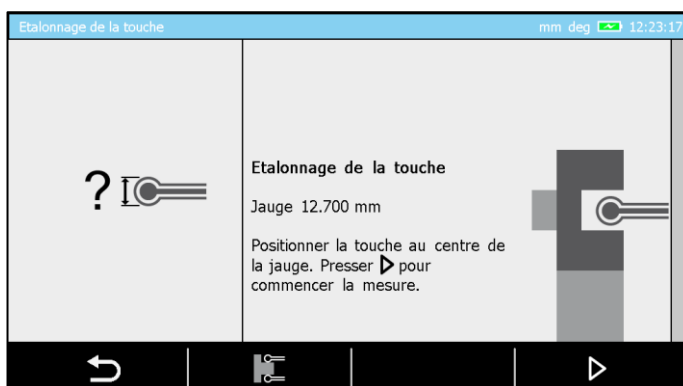



Each time the procedure for determining the probe constant is started, the above page is automatically displayed.

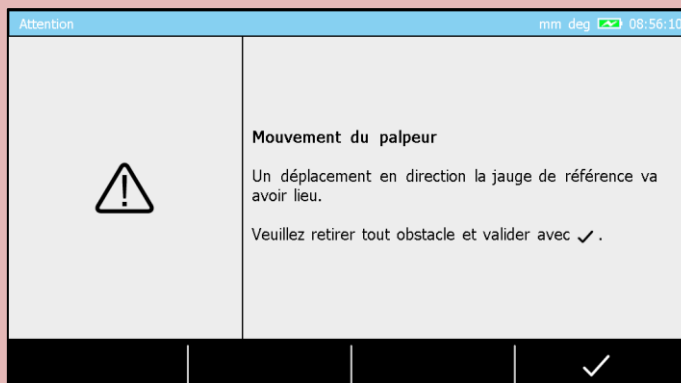

A warning message will be displayed. Before activating the process for automatic determination of the probe constant, the insert must be positioned at the height of the master piece. As this displacement is done automatically, the following message will be displayed to avoid any collision with another object.



As the probe head positioning on the pole is not fixed, the user has to correctly set the desired height, so that the probe moves to the height corresponding to the midpoint of the masterpiece groove/rib.



The procedure can be started clicking on  on the keyboard or  on the screen.

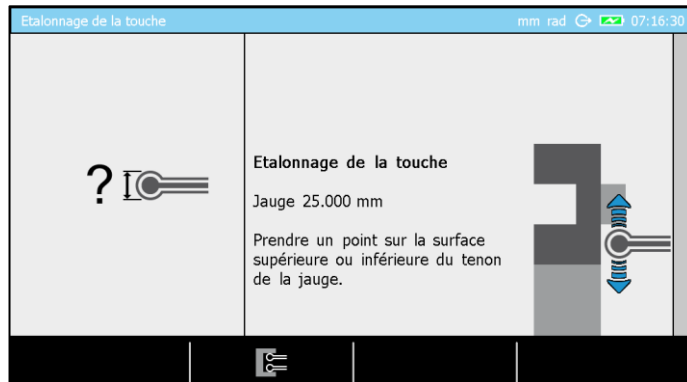

The probe positions itself automatically at the height of the centre of the reference when the user activates the procedure for determining the probe constant. This height can be set in the system options  depending on the probe head positioning on the pole.

The groove measurement process is active by default. Most of the time, measurements are carried out using a ball probe. However, if the user wants to define the probe constant by measuring the rib of the master piece, the user first has to change the mode by pressing the key .



| Definition of keys | |
|-----------------------------------------------------------------------------------|-------------------------------------------------------------------------------------------------|
|  | Change the process for a definition of the probe constant using the rib of the master piece. |
|  | Change the process for a definition of the probe constant using the groove of the master piece. |

Once the process is finished and the probe constant defined, a calibration block is automatically created in the measurement list of the mode. The measurements can then start in ST2  mode.

The next step is to define the reference as shown in the following image.

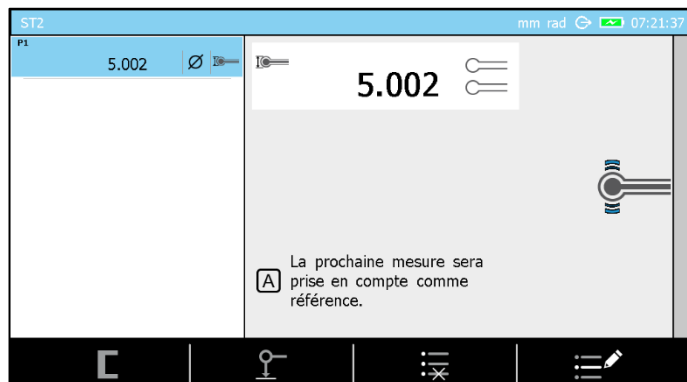

12 PRINCIPLES OF MEASUREMENT

12.1 Generality

Before using the measuring station TESA μ -HITE, it is important to remember that the way in which the values are measured is determined by the measurement problem. It is essential, that the user can define the nature of the measurement process according to the application, in order to quickly get reliable results.

In general, it is important to ask yourself the following basic questions:

- Does the measured value require a single or double probe hit?
- Does the measurement require an inversion of the probing direction?
- Do you have to measure with or without detection of the culmination point?
- Does the measurement sequence have to take into account only one (1D) or two coordinates (2D)?
- Which accessory fits the most with the desired measurement?

These questions are the first step to guarantee ease of measurement with correct metrological results.

12.2 Probe support

It is very likely that during the use of the instrument, the type of application the user will be confronted will imply accessories changes in order to guarantee a reliable and precise measurement. Mounting or removing a probe or probe support is a process that requires to be careful and done in a correct way. Indeed, not mounting it correctly could lead to significant measurement errors.

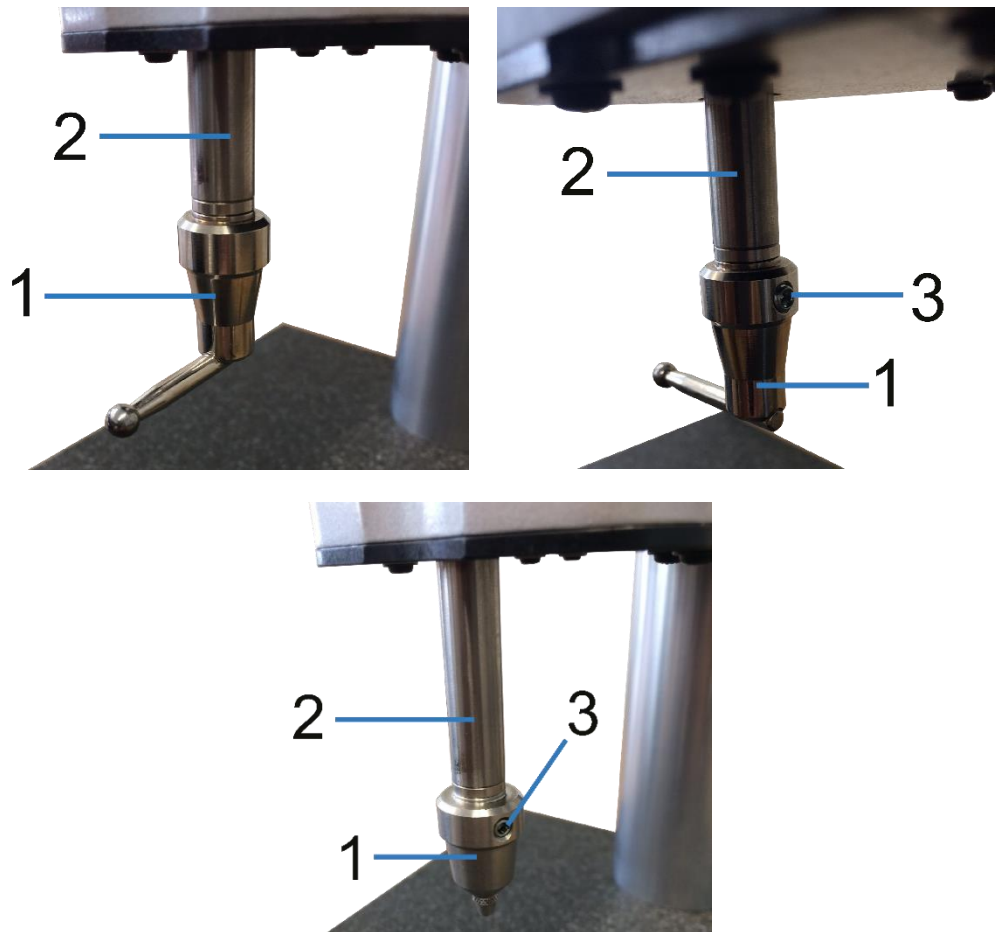

 In order to guarantee the reliability of the measured values, it is necessary that the following condition is met: probe 1 has to be firmly attached to axis 2. Make sure that screw 3 on the probe is tightened. This procedure is the same for all types of probes and supports.

12.3 Measurement modes

Once the workpiece is known and the desired dimensions to be measured are correctly defined, the user has the possibility to choose among several measuring modes:



ST1

Measurement with unidirectional probing



ST2

Measurement with bi-directional probing



MAX, MIN, Δ

Detection parallelism errors



ANGLE

Angle measurement



CALCULATRICE

Allows you to calculate by manually entering the values or using the results of previous measurements.

12.4 ST1 & ST2 philosophy

The two main modes integrated in the height gauge range are defined by the names *ST1* and *ST2*. These are the most frequently used modes. They can directly be selected via the main menu of the measurement software, which can be displayed at any moment by pressing key .

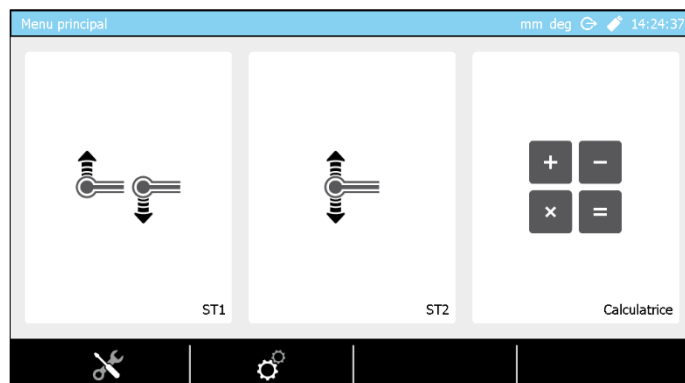

The major difference between these two measurement modes is closely linked to the features (height, diameter etc.) that will be determined during one measurement sequence. The determination of certain features does not require an inversion of the probing direction, while others entirely depend on it.



| Mode | Description |
|------|------------------------------------------------------------------------------------------------------------------------------------------------------------------|
| ST1 | <ul style="list-style-type: none"> • Lengths measurement in only one probing direction. • The calibration of the probe is not necessary. |
| ST2 | <ul style="list-style-type: none"> • Lengths measurement in two probing directions. • The calibration of the probe is mandatory. |

Each one of the two modes has been developed in order to best suit the different application cases and possibilities of use. The flexibility of mode *ST2* allows you to measure any elements, while *ST1* mode minimises the time of access to the measurement (avoiding the probe calibration process) and allows you to use accessories that cannot be easily calibrated with the master piece.

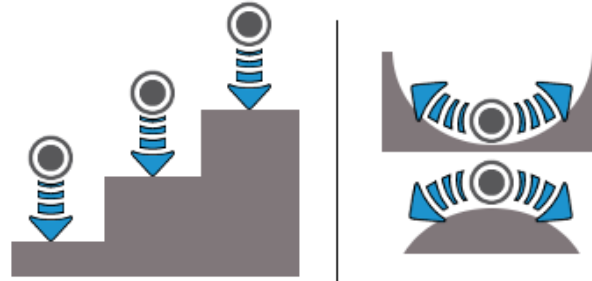

Measurement without inversion of probing direction

In the above examples, all heights are measured by down hits. All measurements therefore have a similar probing direction.

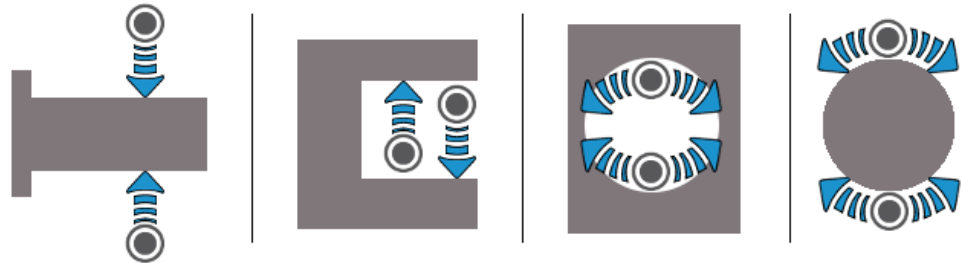

Measurement with inversion of probing direction









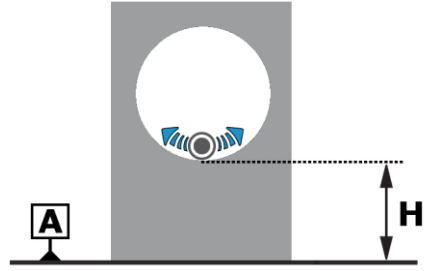

The above examples show that the measured elements require two hits, one by pushing upward and one downward. This is called a measurement that requires an inversion of probing direction as the two measurements have an opposite direction.

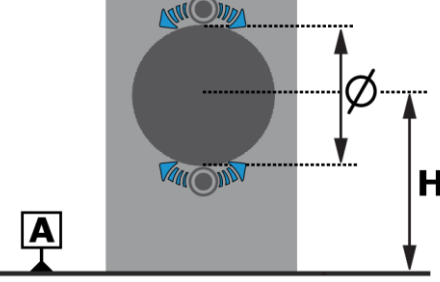

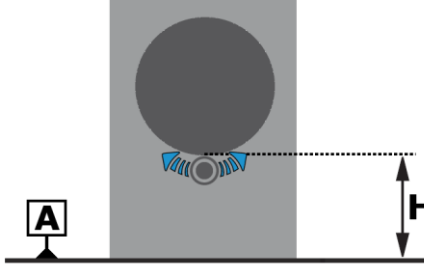

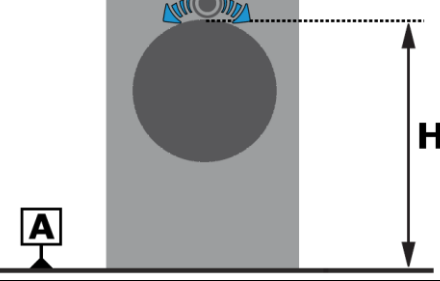

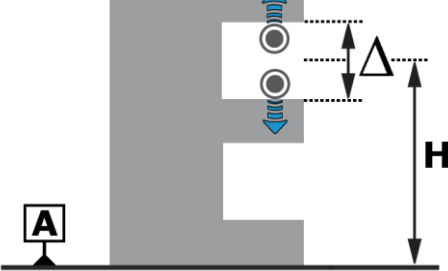
12.5 Measurement functions

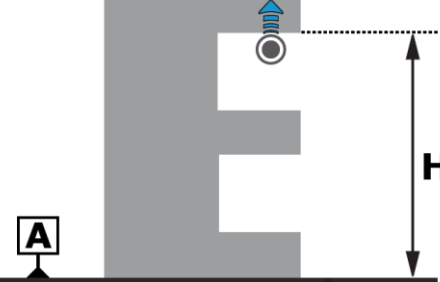
The list of measurement functions is defined by two types of keys:

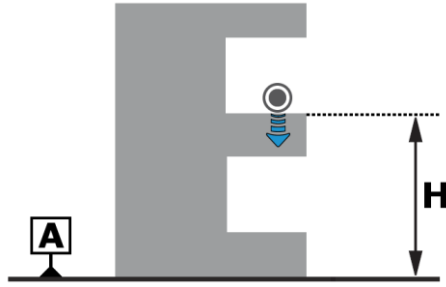
- Action keys (single or double probing)
- Calculation keys

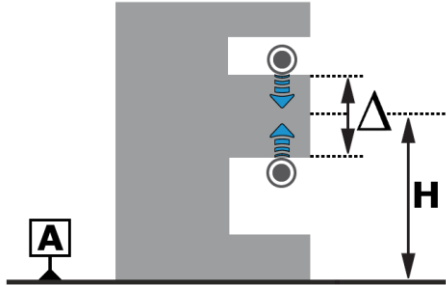
| Action keys | Measurement examples |
|-----------------------------------------------------------|----------------------|
| <p>Bore measurement</p> | |
| <p>Measurement of an upper internal culmination point</p> | |

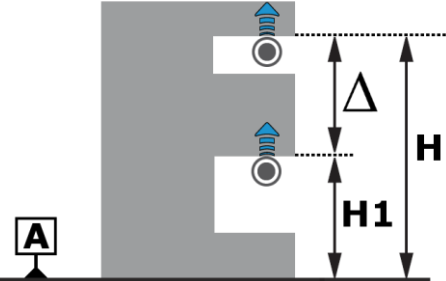
| | |
|-----------------------------------------------------------------------------------------------------------------------------------------------|--------------------------------------------------------------------------------------|
|  <p>Measurement of a lower internal culmination point</p> |  |
|  <p>Axis measurement</p> |  |
|  <p>Measurement of a lower external culmination point</p> |  |
|  <p>Measurement of an upper external culmination point</p> |  |
|  <p>Groove measurement</p> |  |
|  <p>Upper point measurement</p> |  |

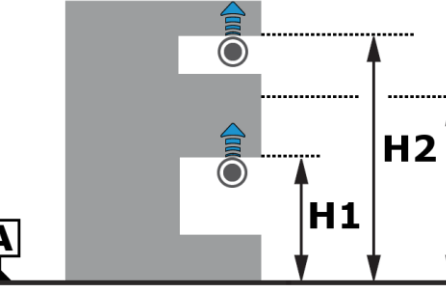
|  <p>Lower point measurement</p> |  |
|---------------------------------------------------------------------------------------------------------------------------|--------------------------------------------------------------------------------------|
|  <p>Rib measurement</p> |  |
| Calculation key | |
|  <p>Difference between two values</p> |  |
|  <p>Average between two values (H)</p> |  |

12.6 Single probing

The automatic single probing process is completely automatic, once the user has chosen an action from the control panel keyboard.

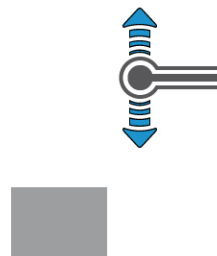

Process

1. Position the probe close to the zone to be measured

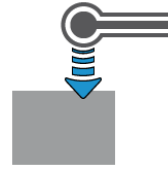

2. Make sure that there is no element between the probe and the zone to be measured that could impede the displacement of the probe.



3. Start the measurement by activating the key  or  from the panel keyboard.

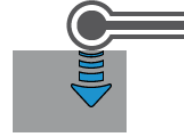

4. As soon as the probe gets in contact with the point to be measured, the system ensures a constant probing force. After a stabilisation period, the measurement will be saved and then displayed on the control panel. **A beep will inform that the measurement process is over.**

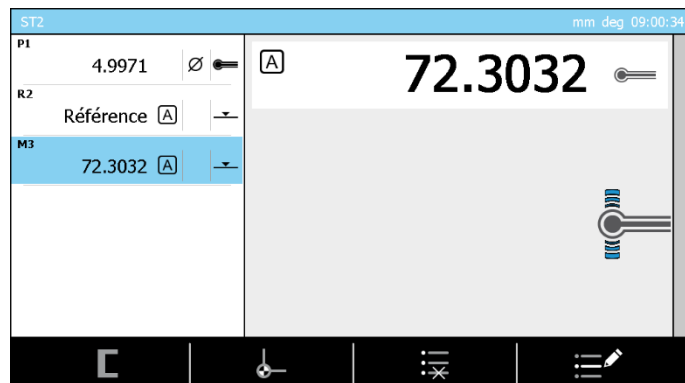



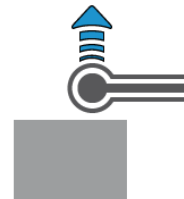

5. As soon as the measurement is finished, the probe will automatically retract. The retract distance is defined in the system parameters.



6. Proceed the same way for the next measurements.

12.7 Culmination point measurement

The type of measurement of the culmination point is intrinsically defined by the selected keyboard action. The software knows the nature of the point to be measured from the selected process:

-  Minimum internal culmination point
-  Maximum internal culmination point
-  Minimum external culmination point
-  Maximum external culmination point







Process

1. Place the probe inside the bore.

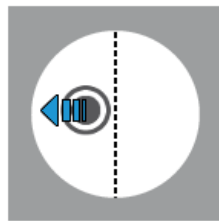

2. Displace the probe slightly to one side of the culmination point (visually).



3. Select an action key on the keyboard , ,  or . The height gauge will move in the required direction in order to establish contact with the workpiece to be measured.

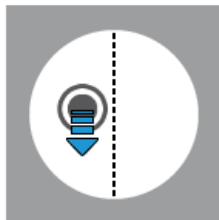

4. Once the contact is established, it is important to wait for the validation of the software in order to proceed with the displacement of the probe in the bore/axis to be measured.

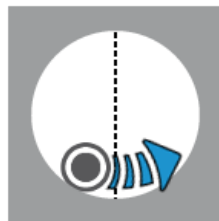

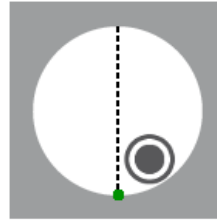

5. Once the minimum (or maximum) point passed, the software will issue a beep. The probe will retract (displacement defined in the system parameters) and stop.

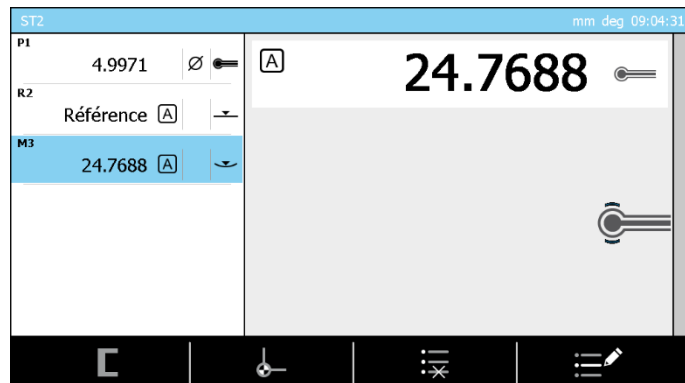

6. The result is automatically displayed on the screen of the control panel.



12.8 Bore measurement

The first steps of measuring a bore or axis are the same as the steps described in previous chapters. The only difference is the keyboard action selected. Now you have to either activate  for axis measurement, or  for bore measurement.

1. As soon as the first culmination point has been determined, the probe will automatically move in the direction of the second point in order to be positioned in contact with the opposite part of the element to be measured.

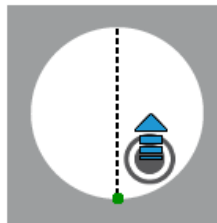

2. Once the contact established, it is important to wait for the validation of the software in order to proceed with the displacement of the probe in the bore/axis to be measured.

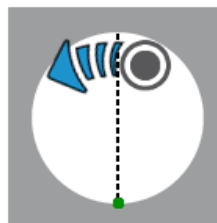

3. Once the minimum (or maximum) point passed, the software will issue a beep. The probe will retract (displacement defined in the system parameters) and stop.

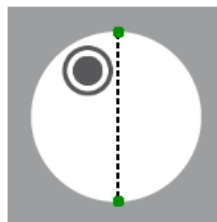

4. The result is automatically displayed on the screen of the control panel.

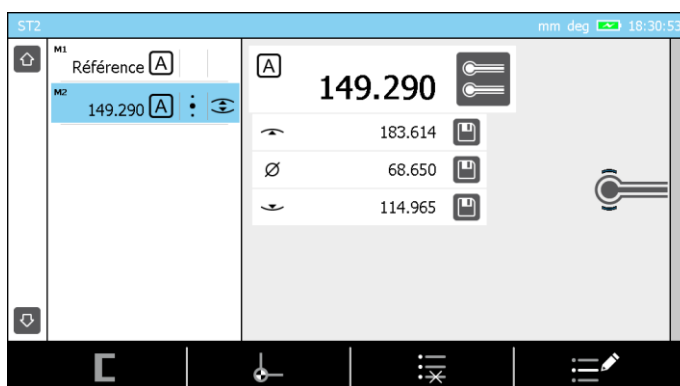

13 ST1 MODE

13.1 Generality

The access to *ST1* mode does not require the determination of the probe constant. This has a direct impact on carrying out a measurement sequence. All measurements regarding the same reference have to be carried out by probing in a direction similar to the one chosen when the active reference has been captured.

| | | Probing direction (during the same measurement sequence) | | | | | |
|--------------------------------------|---|-------------------------------------------------------------|---|---|---|---|---|
| | | 9 | 3 | 6 | 8 | 2 | 5 |
| Probing (capturing the reference) | 9 | • | • | • | - | - | - |
| | 3 | • | • | • | - | - | - |
| | 6 | • | • | • | - | - | - |
| | 8 | - | - | - | • | • | • |
| | 2 | - | - | - | • | • | • |
| | 5 | - | - | - | • | • | • |

Example of a measurement sequence when the active reference has been probed down or up.

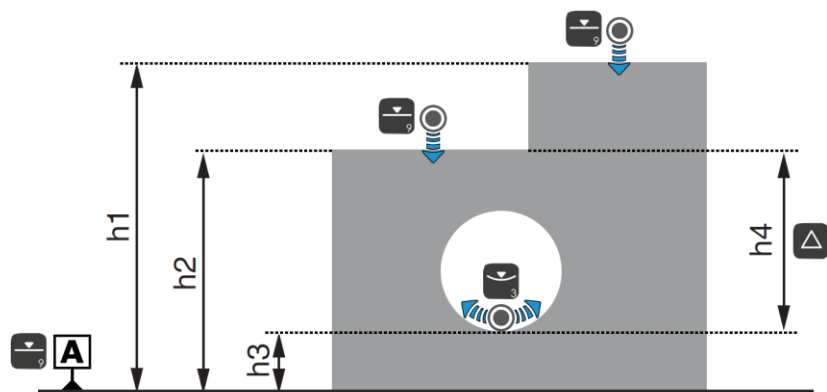

Example of measurements when the active reference has been determined by probing down.

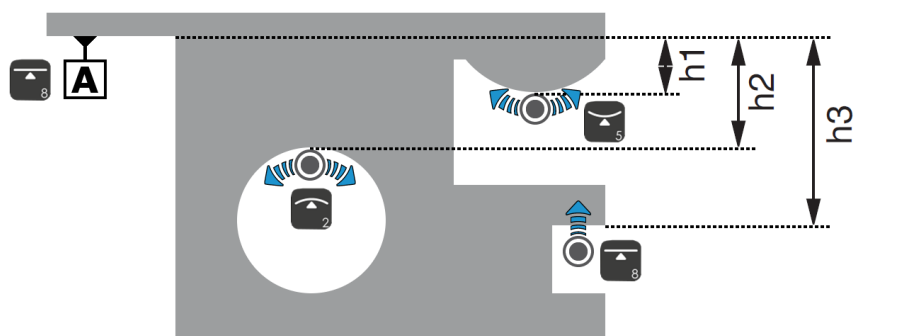

Example of measurements when the active reference has been determined by probing up.



The ST1 mode can accept several different references. This means that the measurements stored in the memory may not have been taken in the same direction if they are depending on two different references.

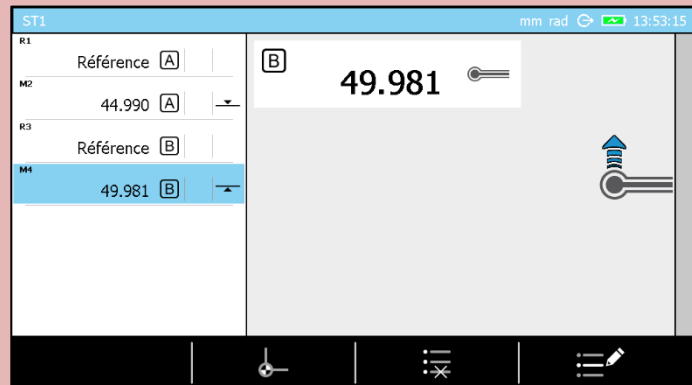

In this example, measurements M2 and M4 are probed in two opposite directions. This is possible as these measurements depend on two distinct references A and B also captured in two opposite probing directions.

This mode is accessible from the main menu by activating the key at any moment.

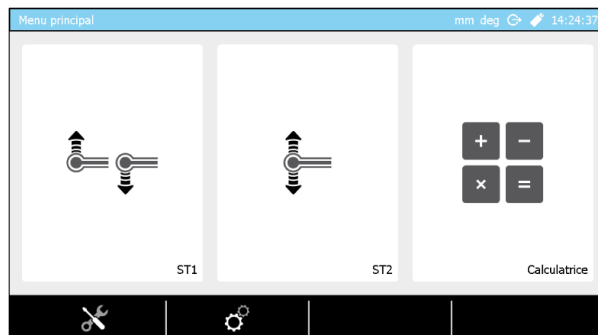

13.2 Capturing the reference value

In ST1 mode, reference values are always captured with single probing.



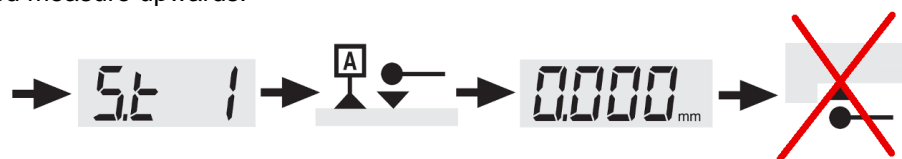

This reference value can be defined by a single probe hit (,) or by measuring a culmination point (, , ,). As explained before, the probing direction used when capturing this reference value will determine the probing direction of the following measurements.

Thus, the following process is impossible as the reference is taken downwards and the desired measure upwards:





Any measurement with inverted probing direction compared to the direction defined when the reference value has been captured, will generate a warning beep. Therefore, no point is stored in the memory.

13.3 Reference value management



In *ST1*  mode, the reference values are managed the same way as in *ST2*  mode.
For further information, please refer to ST2 chapter.



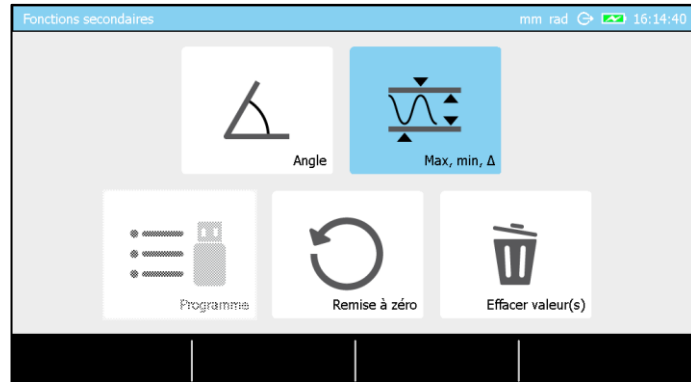

13.4 Secondary functions *FX*

In *ST1*  mode, secondary functions are accessible via the key .



- Angle measurement
- Min, max, Δ
- Programs' management and tolerancing
- Delete all measurement blocks and delete reference values in the memory
- Delete one or several measurement blocks

 **The *Min, Max, Δ*  mode is only active and selectable if the reference value has already been measured before.**

 **Once the *Angle*  or *Min, max, Δ*  mode selected, it is possible to go back to *ST1*  one by pressing the key .**

13.5 Context-based actions

All actions of *ST1* mode, displayed and usable from the bar at the back of the screen are also displayed and usable with *ST2* mode. *ST2* mode integrates the actions of *ST1* mode.
For further information, please refer to ST2 chapter.

14 ST2 MODE

14.1 Generality

Each time when entering $ST2$ mode, it is necessary to calibrate the probe . Once this has been carried out, you can either probe up or down for any measurement sequence.

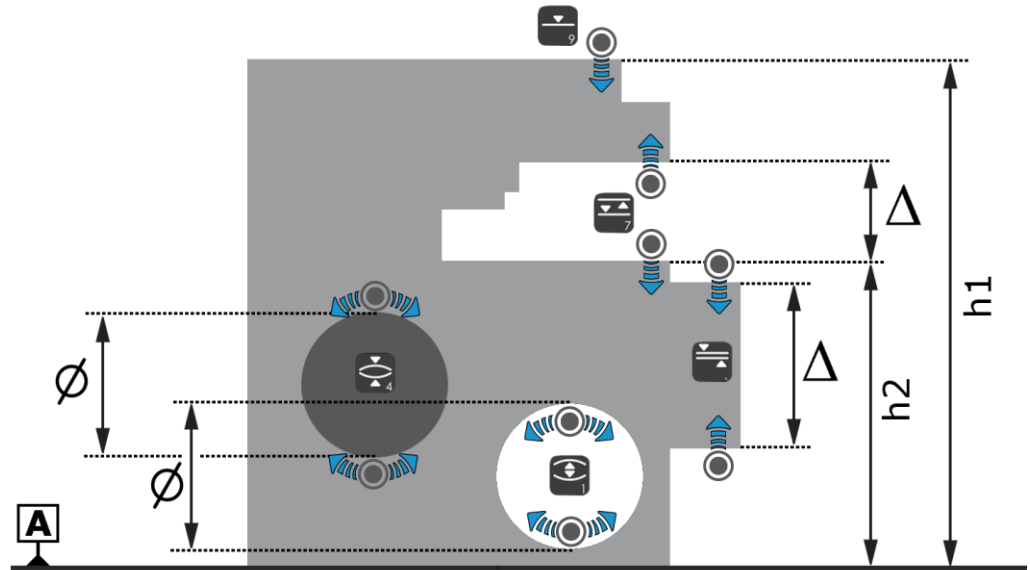

Examples of a measurement sequence in $ST2$ mode

This mode is accessible from the main menu by activating the key at any moment.

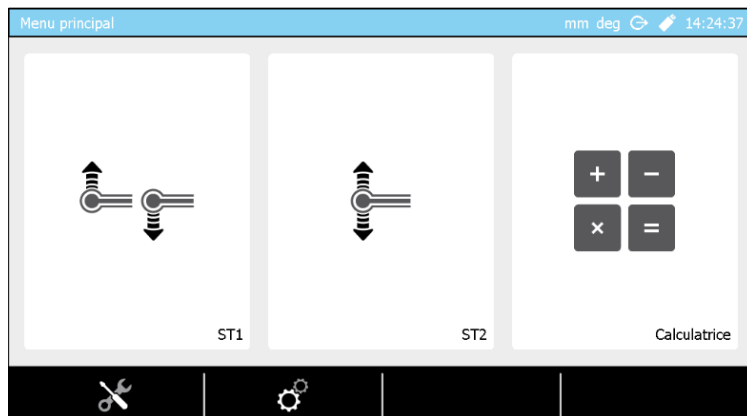

14.2 Probe calibration

When entering $ST2$ mode, the probe calibration process starts automatically.

The procedure for determining the probe constant is only re-executed if the user leaves the $ST2$ mode and entered in another mode ($ST1$).

Thus, an intermediate modification of a system parameter (in) or the use of the integrated calculator does not imply a re-determination of the probe constant.

14.3 Capturing the reference value

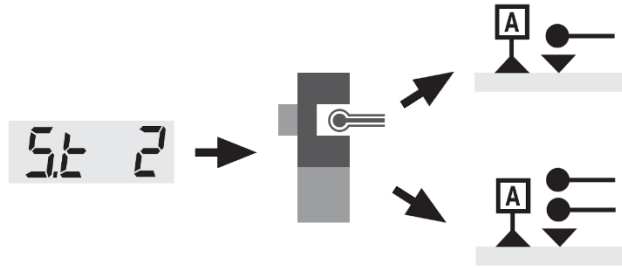

When entering $ST2$ mode, once the probe calibration has been performed, the reference values measurement can be done by simple or double probings.

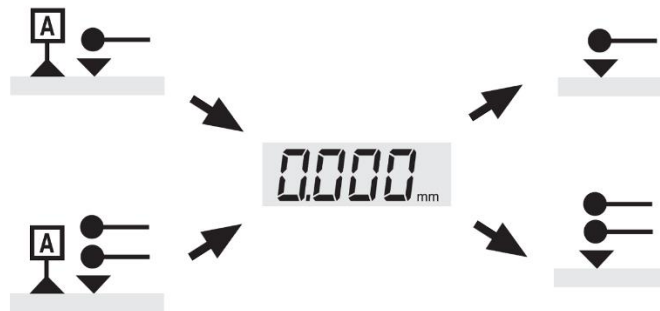

Once this reference value has been captured, the measurements can be carried out with one or two probe hits (selectable by the user).



14.4 Single & double probing

The concept of single and double probing has been developed in order to allow the direct measurement of certain elements and quick access to their features. While single probing  enables only height measurements in order to gain some time, double probing  is the way to minimise the number of measurement steps and to improve cycle time. Therefore, everything depends on the application.

Note that double probing allows you to position a reference value at levels that would be impossible in *ST1*  mode:

- Centre of groove or rib
- Centre of bore or axis

Other configurations are also possible (example: between two circles) but used less frequently.

As each application is different, it is the responsibility of the user to define the most appropriate measurement steps. In many cases, a similar result can be reached via two measurement sequences. Only their steps are different.

In order to illustrate single and double probing, two different measurement procedures with the same result are shown below. Note that each measurement block corresponds to one step that has to be carried out independently of the others.

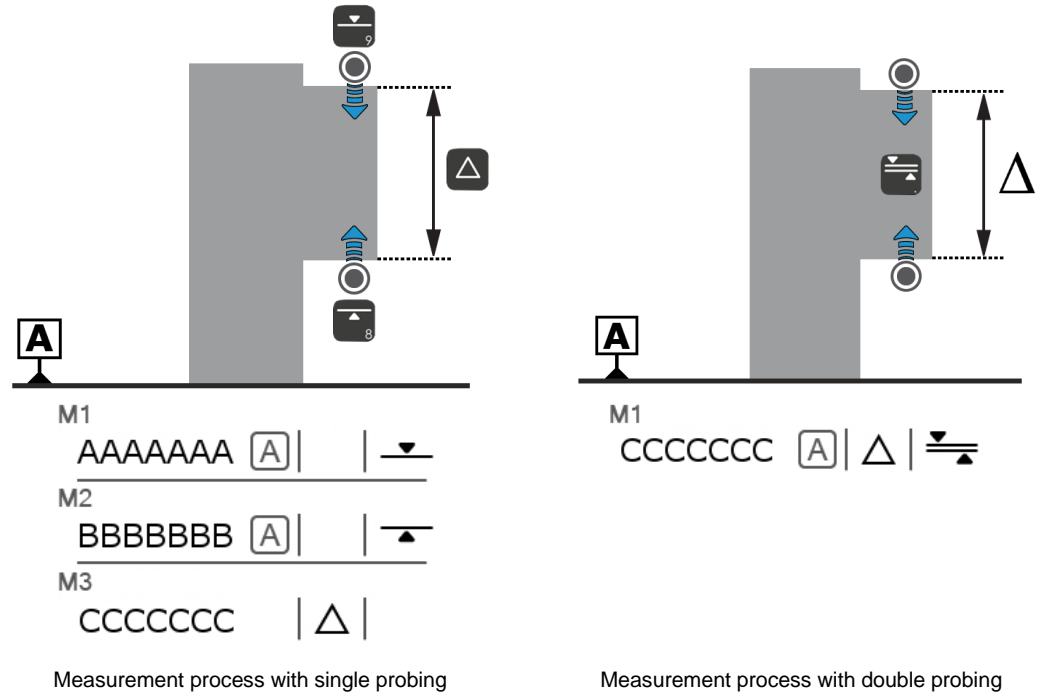

The two examples above clearly show that in certain cases, it is better to go for “double probeings” measurements. The first solution requires 3 measurement blocks (2 measures and one calculation) to get a result, while the second one only requires one.

It is important not to mix single/double probing and ST1/ST2 concepts. Here is an overview:

| | |
|-----------------|--------------------------------------------------------------------------------------------------------------------------|
| ST1 mode | <ul style="list-style-type: none"> • Single probing only • Probing in reference's direction only |
| ST2 mode | <ul style="list-style-type: none"> • Single or double probing possible |

On the μ -HITE, the number of probe contacts for measuring an element is intrinsically linked to the activated key on the control panel.

For example, corresponds to a up single probing, while allows you to start a double probing measurement going up and down.

| Icon | Description |
|------|------------------------------------------------|
| | Two probe hits |
| | Two probe hits The upper point is measured. |
| | Two probe hits The lower point is measured. |
| | Two probe hits Both points are measured. |
| | One probe hit |
| | One probe hit The point is measured. |

14.5 Secondary results

When measuring an element by double probing, several results are displayed on the screen. In addition to the main value, 3 secondary values can also be available (in green below).

The main value is automatically saved in the measurements list, which is not the case for the secondary results.

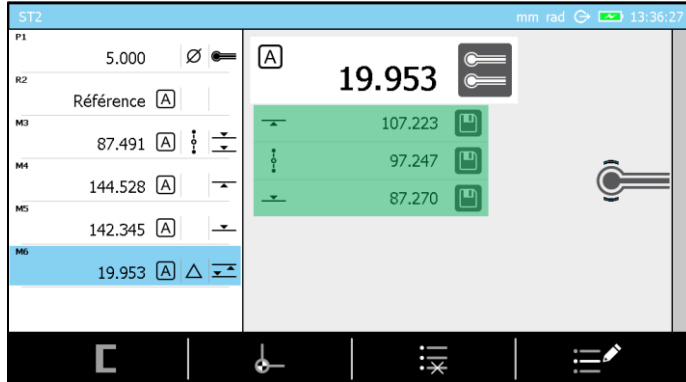

In the screenshot above, the secondary values are:

| Icon | Description | Value |
|------|-----------------------|---------|
| | Probing up | 107.223 |
| | Distance between hits | 97.247 |
| | Probing down | 87.270 |

In certain cases, a secondary result could also be a wanted one. Click on the key , which allows you to save the value in the measurements list.

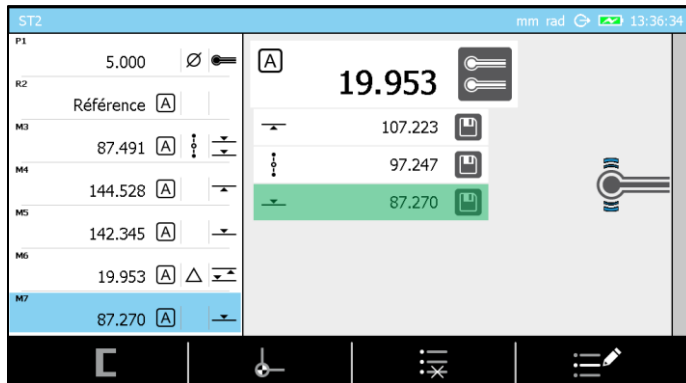

The image above shows that the result corresponding to a down probing has been stored in the measurement list.

14.6 Secondary functions FX

In ST2 mode, secondary functions are accessible via key .

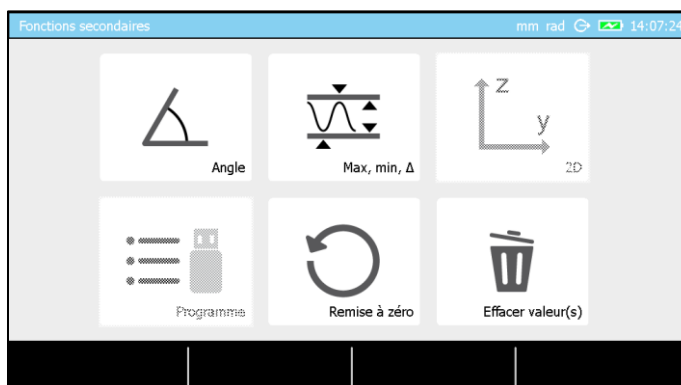

- Angle measurement
- Min, max, Δ
- Measurements in 2 dimensions
- Program management and tolerancing
- Delete all measurement blocks and delete reference values in the memory
- Delete one or several measurement blocks

The *Min*, *Max*, Δ and *2D* modes are only active and selectable if the reference value has already been measured before.

Once *Angle* , *Min*, *max*, Δ or *2D* mode is selected, it is possible to go back to ST2 mode by clicking on key .

14.7 Indirect reference (PRESET)

This function allows you to enter numerical values, in particular for capturing dimensions with a reference point that cannot be probed directly. The distance between the chosen surface to be probed and the reference point used has to be known at least in the form of a theoretical dimension with a positive or negative sign. This indirect reference can be found above or below an element accessible for probing.

1. In ST1 or ST2 mode, the user has to press first, in order to manually enter the preset value.
2. The following step is the definition of the measurement reference. In our example, this reference value is only a fixed point used to define the indirect reference.

Once steps 1 and 2 are finished, all measurements will be calculated according to the indirect reference A that corresponds to the height of the reference taken at step 2 + the value of step n°1.



The option can only be selected when the software requires to define a measurement reference. Any modification of the value of the indirect reference will implicate a redetermination of the measurement reference.



14.8 A&B references management

The μ -HITE offers the possibility to work with two measurement references called A and B at any moment. You will automatically be asked to define a reference in the following situations:

| Mode | Description |
|------|--------------------------------------------------|
| ST1 | When you enter into this mode for the first time |
| ST2 | Following a calibration of the probe |

At the same time, it is also possible to force the definition or re-definition of a measurement reference by:

- pressing the key , which will restart the process of determining the active reference
- pressing the key  or  on the control panel for 3 seconds. As a result, the last measurement block in the measurement memory (calculated or measured) is taken into account as active reference value.

A reference can be activated by pressing the key  or  on the control panel. This is only possible if the reference value has been defined previously. Otherwise, an error beep will warn you that this reference cannot be used for the moment as it has not been defined yet.

14.9 Delete last measurement block

It is possible to delete the last measurement block in the memory at any moment via the key . This deletion is independent from the selected block(s) in the measurements list.

14.10 Edit a measurement block

The name of a selected measurement block can be edited at any time if it is previously selected in history.

This can be done with button .

 **When calculating, it happens that the name of the newly created block is automatically defined according to the previously selected blocks for calculation (example “M3-M5”). This name is informative and can also be modified via the editing key.**

Below an example of introducing a block name:

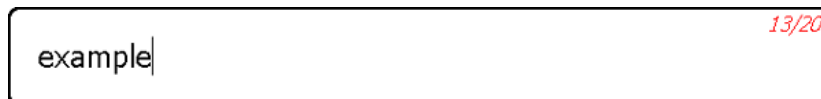

On the top right side of the screen, the total number of characters available for determining the name as well as the number of characters already used is defined.

14.11 To run a probe calibration

The key  will allow you to force a probe recalibration.

14.12 Distance between two heights

It is possible to calculate the distance between two heights (calculated and/or measured) using the key Δ of the control panel. However, it is important to know prior to the measurement which results (measurement blocks of the list) have to be taken into account during the calculation.

There are two options for the user.

| Case | Description |
|--------------------------------------------------------------------------|----------------------------------------------------------------------------------------------------------------------------------------------------------------------------------------------------|
| Only one block of the memory is selected (regardless of which one it is) | Regardless of the block that has been selected, it is the distance between the two last valid blocks in the list that is calculated. $M_{\text{last block}} - M_{\text{second last block}}$ |
| Two blocks of the list are selected | The distance is calculated as follows: $M_{\text{selection 1}} - M_{\text{selection 2}}$ |

14.13 Average between two heights

It is possible to calculate the average of two heights (calculated and/or measured) using the key \div of the control panel. However, it is important to know prior to the measurement which results (measurement blocks of the memory) have to be taken into account during the calculation. There are two options for the user

| Case | Description |
|--------------------------------------------------------------------------|-------------------------------------------------------------------------------------------------------------------------------------------------------------------------------------------------------|
| Only one block of the memory is selected (regardless of which one it is) | Regardless of the block that has been selected, it is the average between the two last valid blocks in the list that is calculated. $(M_{\text{last block}} - M_{\text{second last block}})/2$ |
| Two blocks of the list are selected | The average is calculated as follows: $(M_{\text{selection 1}} - M_{\text{selection 2}})/2$ |

14.14 Selection of a measurement block

In each measurement mode, it is possible to select one of the measurement blocks from the measurements list. Selecting means to position the blue cursor on the measurement block as it is the case for the last block on the below picture.

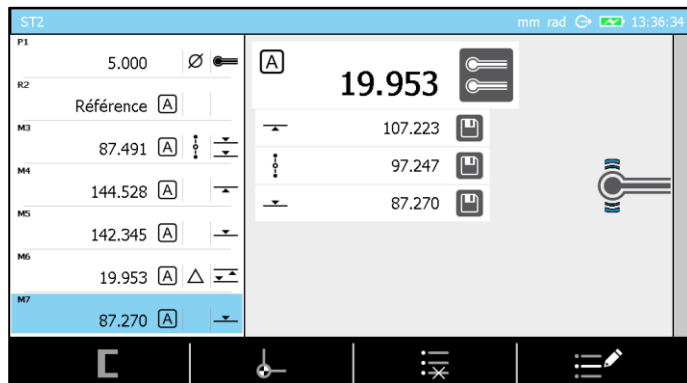



There are two possibilities to do so:

1. Use the arrows \uparrow and \downarrow of your control panel
2. Touch the block directly on the touchscreen

14.15 Two measurement blocks selection

When a calculation involves several measurement blocks, it is important to take into account that the order in which the blocks are selected will have an impact on the final calculation (on the sign of the result).

The multiselection of blocks is mainly used to calculate a height difference  or a middle/average height .

There are two different ways for a multiselection:

1. By quickly clicking two times on the block to be selected directly on the screen.
2. By displacing the focus (blue bar) on the block and pressing the key  of the keyboard.

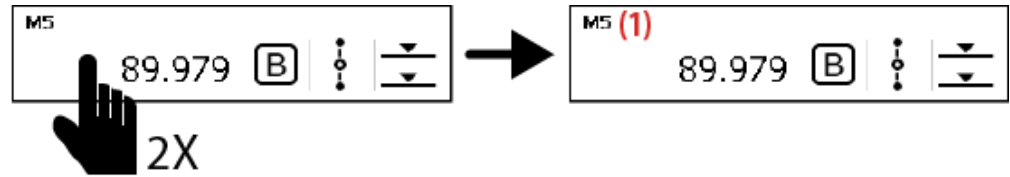

Note that selecting a block will add a (1) or (2) after the number of the block (for example M3 (1)). This number is crucial, as it directly depends on the order of selection and will play a role in the sign of the result.

 **If you would like to deselect a block, you can:**

- **Quickly click two times on the selected block (touchscreen)**
- **Displace the selection on the block and validate the deselection using the key  on the keyboard.**

15 MAX, MIN, Δ MODE

15.1 Introduction

This measurement mode is also called “continued display”. It can be defined as a mode that enables scanning a surface in order to detect parallelism errors in regards to a reference surface.

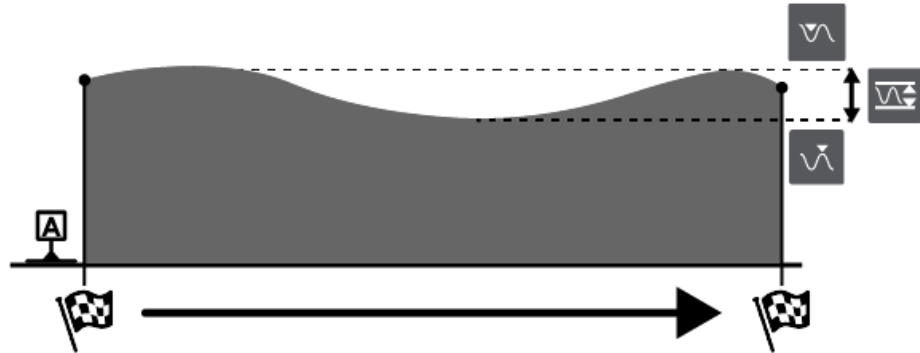

This mode is accessible by pressing the key F_x in $ST1$ or $ST2$ measurement modes.

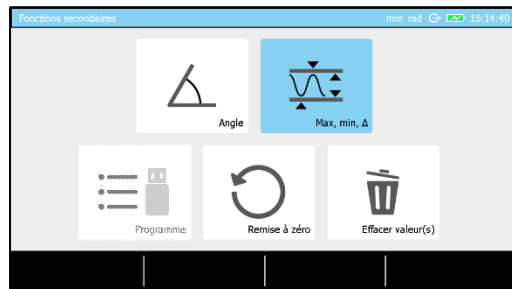

Menu FX from ST1

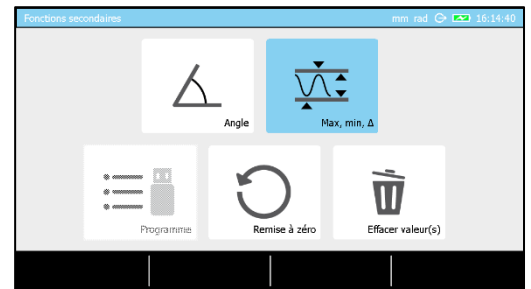

Menu FX from ST1

15.2 Measurement principle

1. Once the measurement mode is activated, position the probe above the surface to be measured.

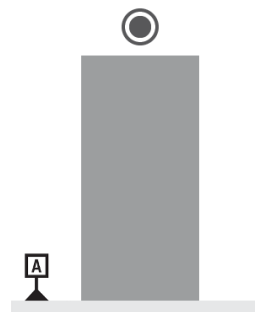

2. Press the key \downarrow or \uparrow that corresponds to the desired measurement direction. The probe will move in the chosen direction in order to establish contact with the workpiece to be measured.

If *Min, Max, Δ* mode has been activated from $ST1$ mode, one of the two keys will be disabled (the one that does not correspond to the probing direction of the active reference).

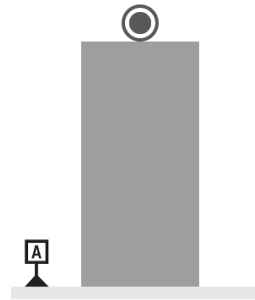

3. Once the pressure on the probe is sufficient to start the measurement, the software will ask you to move the workpiece back and forth, so that the probe is displaced along the whole measurement zone.

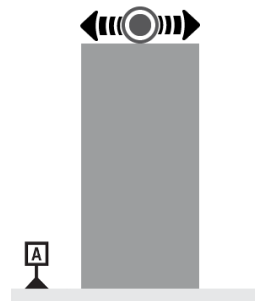

4. Validate and finish the measurement using the key ✓.

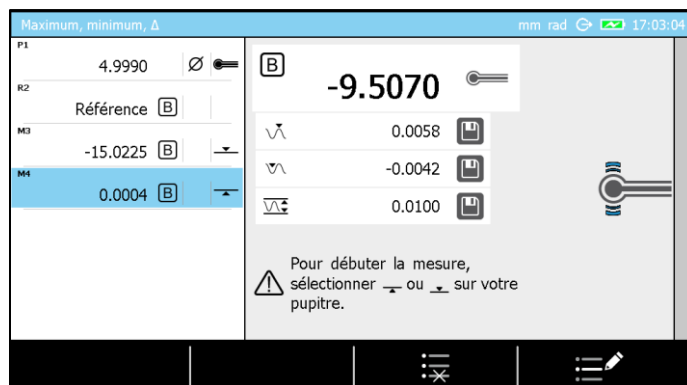

5. Save one or several results in the measurement program/list by clicking on . For example, below the Δ value.

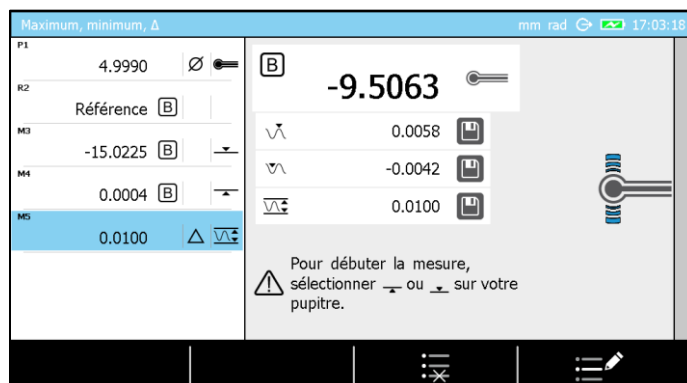

6. Press \downarrow or \uparrow again in order to start a new measurement process, press F_x to go back to ST1 mode (respectively ST2) or Home to go back to the main page.

15.3 Graphic

In some cases, you might need to physically locate the maximum (respectively minimum) position of the measured surface. During the measurement, a bar graph or galvanometer is displayed to allow real-time visualization of the probe position.

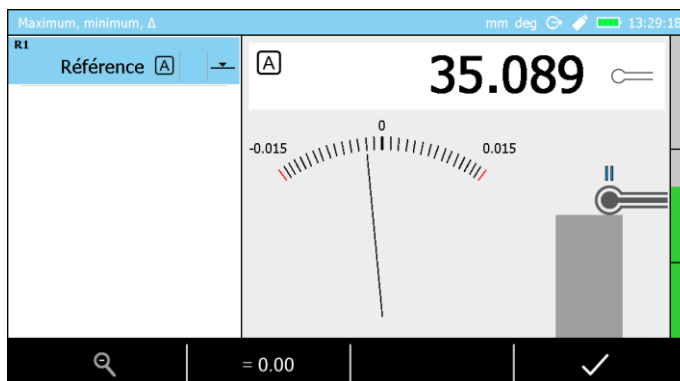

16 ANGLE MEASUREMENT

16.1 Introduction

This mode allows you to measure an angle very easily and in only a few steps. It requires the use of a standard in order to be able to determine the distance X below (we will consider that an additional fixing system is required to position correctly the gauge block n°1 against a surface, this system is not represented in the drawings below).

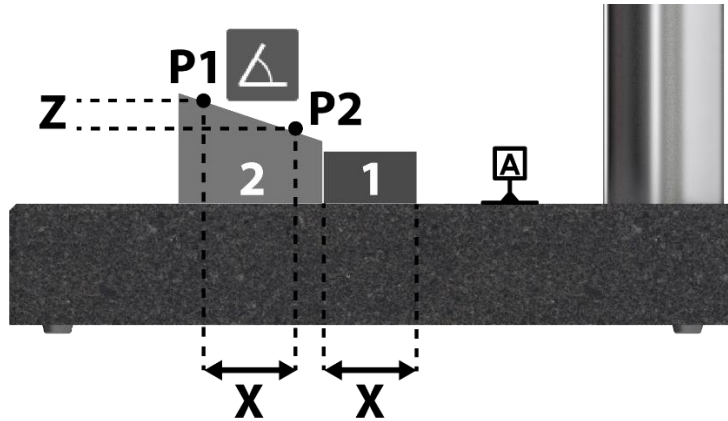

This mode is accessible by pressing the key F_x in ST1  or ST2  measurement modes.

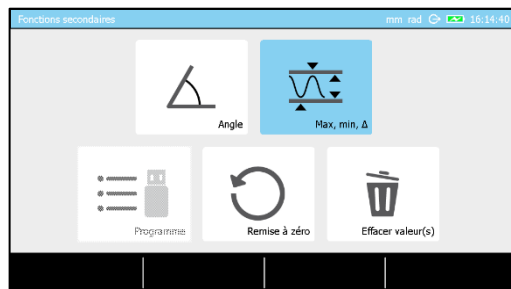

Menu FX from ST1



Menu FX from ST2

Additionally, this mode can also be used to define the internal or external angle of a cone. It is of course up to the user to fix the cone in a way allowing an optimum measurement.

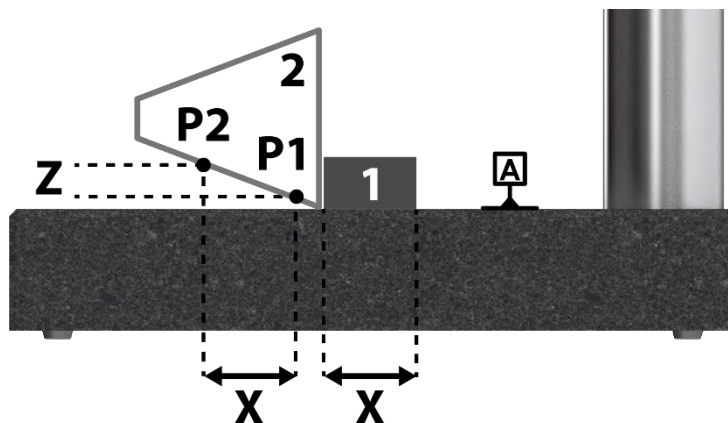

16.2 Measurement principle

1. Once the measurement mode is activated, position the probe above the surface to be measured. You will have to capture the “upper” point of the measurement.





2. Press the key . The probe will establish contact with the workpiece to be measured.



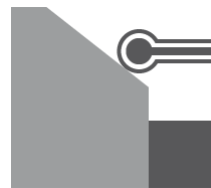

3. Place a gage block (+ intermediate piece) between the workpiece to be measured and the instrument. Measure the second point by pressing . You will capture the “lower” point of the measurement.



4. At this step of the procedure, ΔZ (or Z) has been calculated. It is now necessary to define ΔX (or X), which corresponds to the size of the standard used. There are two possibilities for the user to do so:

- Enter the gage block’s value manually by clicking on . Once the value has been entered and validated, it is necessary to finalise the process ignoring the last steps by pressing  (see step No. 6).
- Continue the procedure and measure the standard by capturing point No. 3.

 As the standard has been turned by 90° in order to be measured, the software uses an option mentioning the Z-coordinate: . However, this is still the ΔX distance.

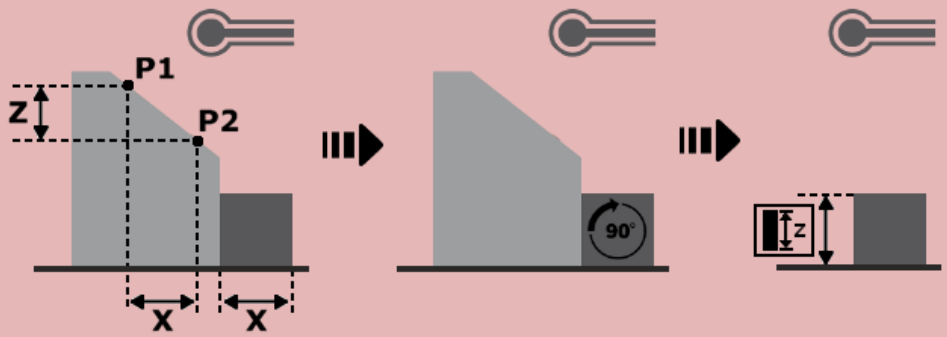





5. Now determine the size of the standard by measuring the last point of the process.



6. The measurement results are displayed on the screen. The angle value is automatically saved in the measurement programme. The values of the secondary results can also be stored in the memory by clicking on .



7. It is possible to restart the process by measuring the first point defining another angle by means of , press  to go back to ST1 mode (or ST2) or  to go back to the main page.

16.3 Cone angle measurement

The steps of the procedure to measure the internal or external angle of a cone are almost identical to those detailed previously in the chapter about flat surfaces. The only difference lies in the nature of the points measured on or in the cone. Indeed, instead of measuring points on a flat surface, in this case the heights will be measured as culmination points.

17 CALCULATOR

17.1 General information

The calculator is a very common object and still indispensable for many different and complex measurements. As it is important to be able to work with the measured values without the need to save them on a device or to write them down on paper, a *Calculator* mode has been integrated into the μ -HITE for more ease of use during the measurement process.



This mode is accessible from the main menu by pressing the key  at any moment.

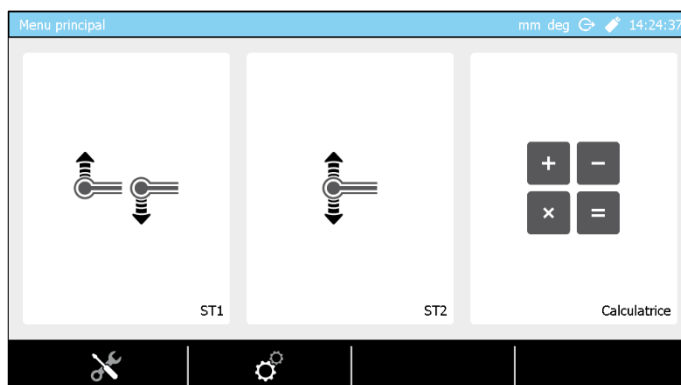

17.2 Concept

The concept of this mode is based on the fact that the user has the possibility either to use it as a standard feature, meaning that the user can manually enter the values that will be used during a calculation or also re-use one or several results of previous measurements (blocks of list).

The mode is presented in the form of a software page split into two distinct parts defined by their function. The zone on the left defines the measurements list. The right zone allows you to enter a value and a measurement function.

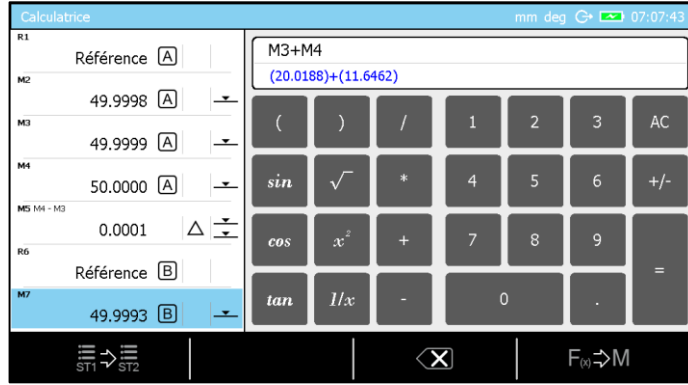

17.3 Use of the measurement blocks

The advantage of this integrated calculator is that the results of previous measurements can be reused for calculation of more complex functions that cannot be defined directly via the control panel.

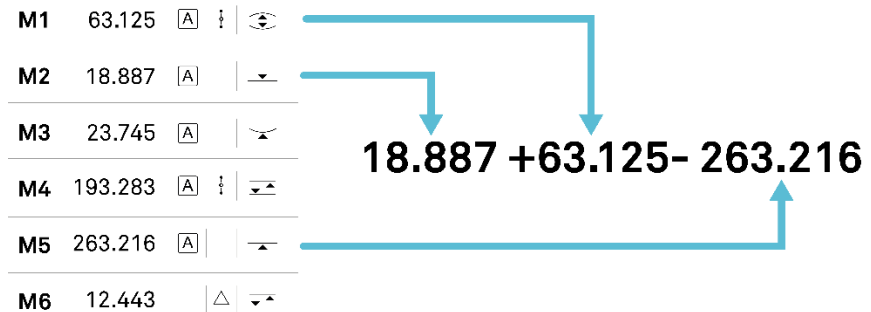

It is important to know in which way the measurement results can be taken into account in the calculation function. You simply have to:

- quickly double-click on the measurement block and the value will automatically be copied in the bar dedicated to writing the calculation function.

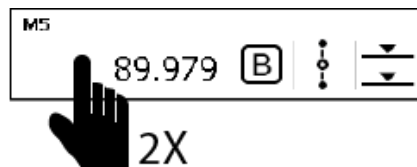

- Move the selection (blue bar) using the keys , , and then validate your choice using .

17.4 Changing measurements list

The two measurements lists of ST1 and ST2 modes are independent from each other. By default, it is the memory of the last mode that has been activated that will automatically be displayed when entering the *Calculator* mode.

However, it is possible to go from one memory to the other by clicking on the contextual action key or .



At each change of measurement list, the function defined in the calculator is automatically erased.

17.5 Customised calculation function

The display of the *Calculator* mode is defined by two lines:

| |
|---------------------|
| M3+M4 |
| (20.0188)+(11.6462) |

The first line corresponds to the function chosen by the user but only includes the labels of the selected blocks. The second line corresponds to the same function but shows the measurement values of the selected blocks.

It is possible to create a customised function block saved it into the measurement list by clicking on the contextual action key  (e.g. in our example, the calculation block created will include the function M3+M4).

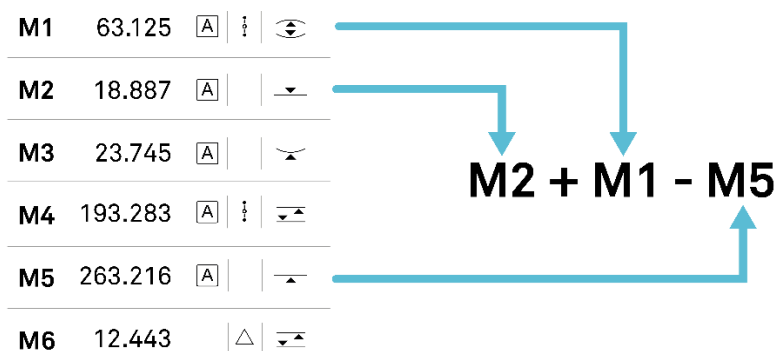

It is possible to recall a customised function that has been stored in the measurements list. To do this, you just need to select the corresponding block and then press  the context-based action.

18 MODE 2D

18.1 Introduction

The μ -HITE is an instrument that is basically used to measure only when being positioned on a reference plane (granite table) (3) or any other similar surface. The measures are then performed in one coordinate direction only (2), orientated perpendicularly to the reference plane (1).

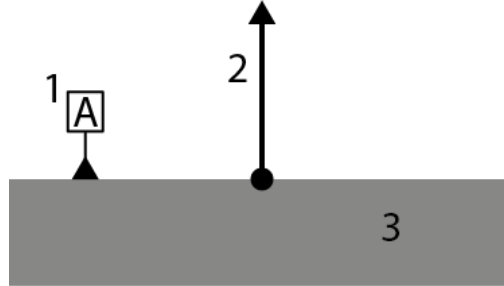

Indeed, it is not possible to proceed to measurement of elements directly in two coordinates without going through measuring steps split by a piece rotation in the directions of the wished coordinates.

The 2D mode is directly accessible from the F_x button of the keyboard when being in ST2 mode.



 The 2D mode is enabled only if a reference has been previously defined in ST2 mode. If you cannot select the 2D mode, return in ST2 mode pressing F_x , then define the reference and come back to the menu with F_x again.

18.2 Principle

The use of the 2D mode implies to go through two steps that will allow then to start the analysis from the received results called “rough data”.

- Step 1: Y coordinates measurement
- Step 2: Z coordinates measurement

The opposite is also valid as the user has the possibility to switch from one axis to the other.

 Even if it is possible to change the reference axis in the middle of the rough data measurement, it is preferable to measure all coordinates of the same axis straight and then change the axis for the second batch of measurements in the other axis.

The first step consists in measuring all Z (or Y) coordinates of axis and bores centres.

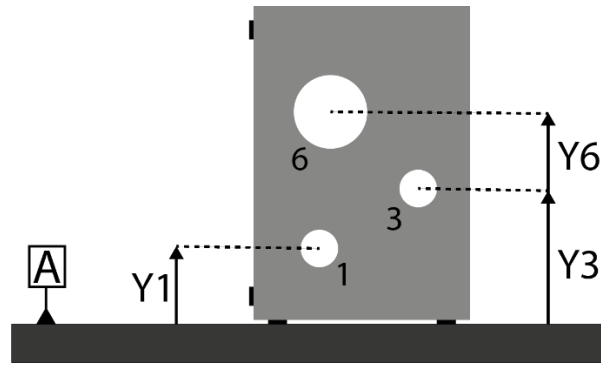

Then the piece is rotated by a wished angle (in our example the part is rotated by 90°) in order to position the part good enough to measure the second Y (or Z) coordinates.

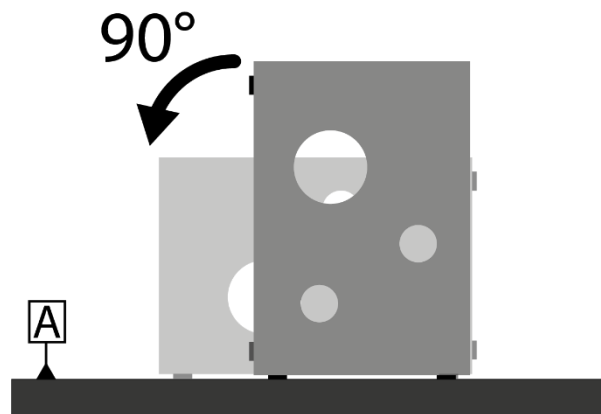

Once rotated, all same elements have to be measured again in a similar sequence as the one followed previously for Y coordinates measurement.

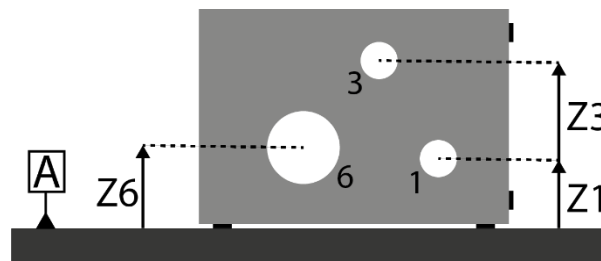



(Y ;Z) coordinates of each element is called « rough data ». It is from these values that calculation will be performed. The analysis is the last step of the process.

18.3 Two measurement possibilities

For each axis or bore measurement, the user has the possibility to find the element centre height following two processes:

Without looking for the culmination point

This way of doing corresponds to the  button of the panel keyboard.

This process is the mean to determine quickly the centre coordinate without getting the diameter of the measured element. Indeed, the below graph shows a H coordinate research through  measuring option. The probe is probably not centred in the bore. Therefore, the

software will determine the H coordinate using the P3 point but the distance between P1 and P2 does not correspond to the diameter of the bore.

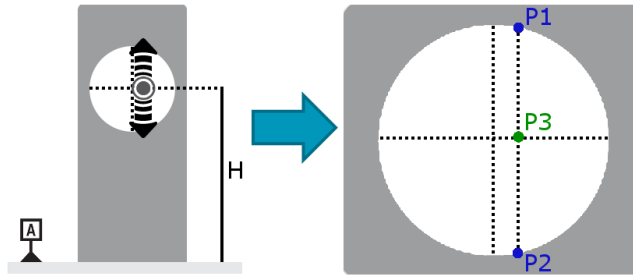

The software will then display only the measured coordinate in the corresponding block (Z in our case).



Looking for the culmination point

This way of proceeding corresponds to and button of the panel keyboard.

On the contrary, using one of the methods for checking the culmination point, P1 and P2 are really the maximum and minimum locations of the bore. This is the reason why, as results, H will be given as P3 coordinate as well as the bore diameter, distance between P1 and P2.

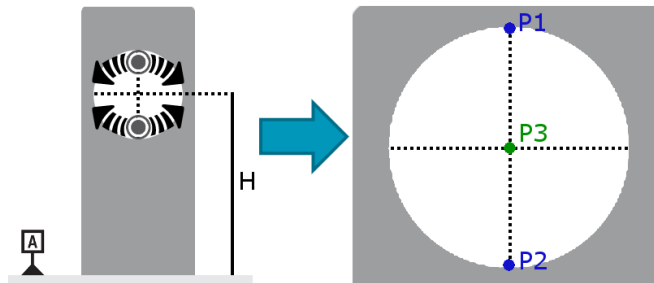

In this case, the software displayed not only the measured coordinate but also the element diameter.

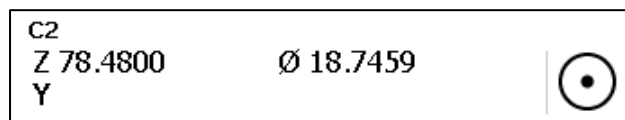

18.4 Application examples

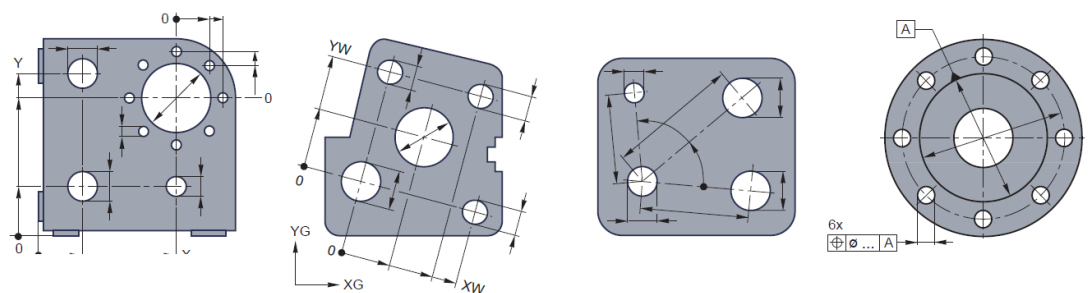

18.5 Step by step example

In this chapter we will show an example in order to clarify the needed steps to determine and get the right rough data. If you want to have more information about how we can analyse the data, please refer to the next chapters.

For this example, we will consider that the angle between the two reference surfaces of our part is perfect, at 90°.

 **Before starting any measurement in 2D mode, it is important to know the angle between the two supporting surfaces of your part on the granite table.**

1. From main menu, enter in ST2.

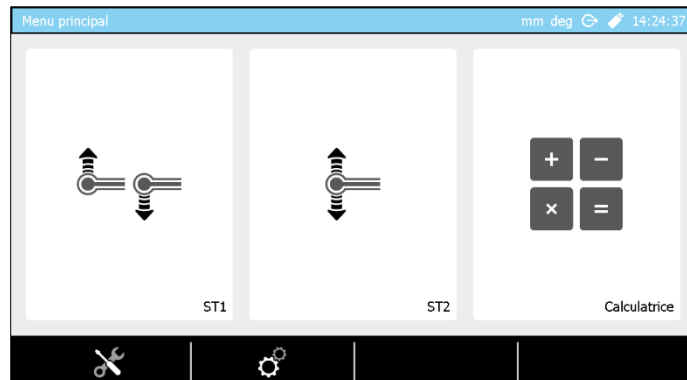

2. Calibrate the probe using the masterpiece delivered with the instrument.

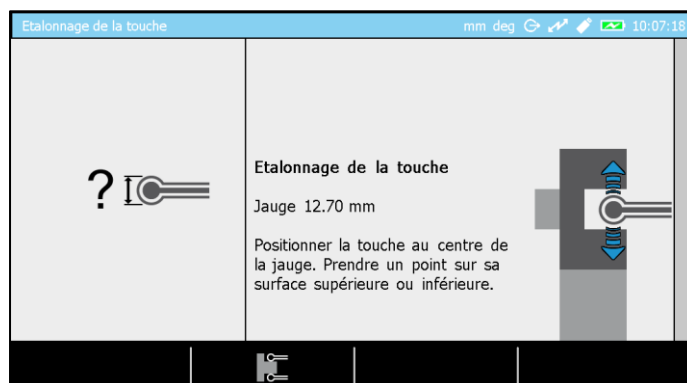

3. Once the probe calibrated you will enter automatically in ST2 mode.

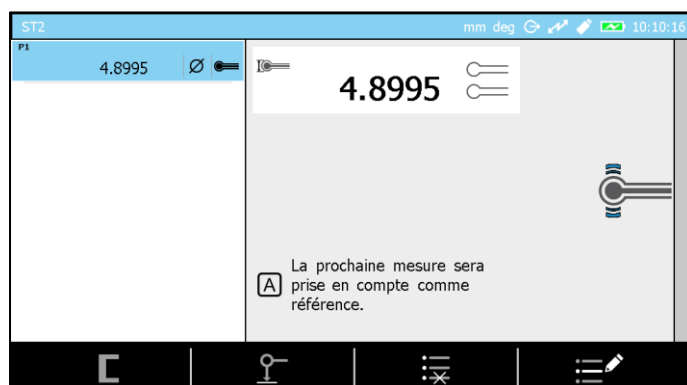

4. Take the reference on the table on which the part to be measured will be placed. Please note that if the reference is not measured, you will not have the possibility to enter the 2D mode.

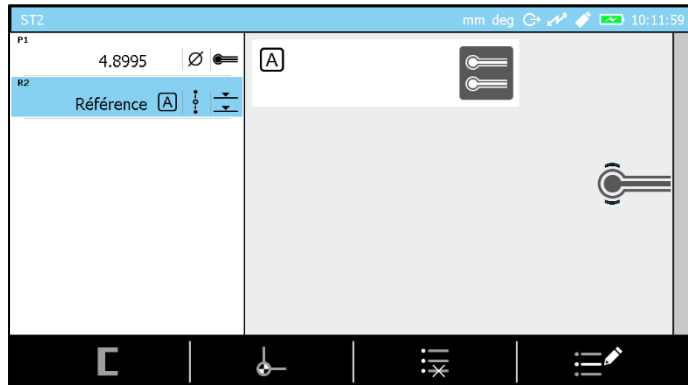

5. Press **F_x** button from panel keyboard.

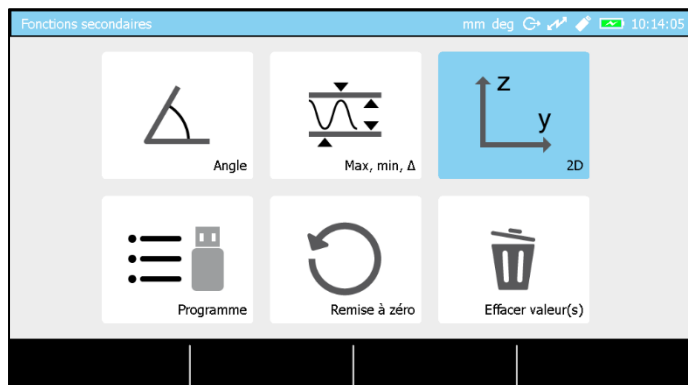

6. Select 2D mode. The software shows now the page dedicated to rough data measurement.

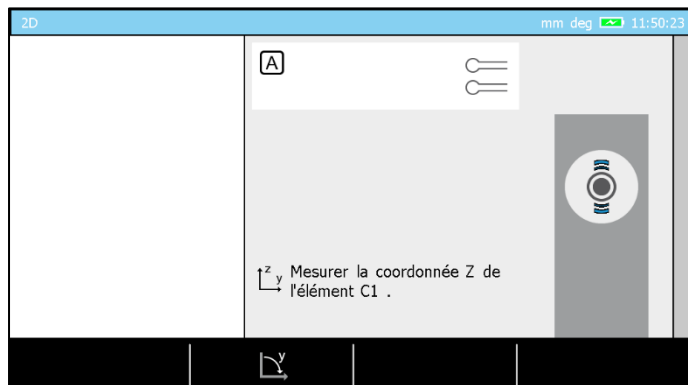

7. Position the piece on the table so that the probe can access all elements you want to be measured.

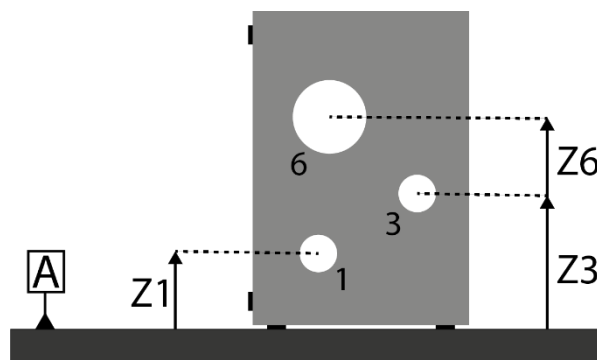

8. Measure each bore following the official processes described before in this document (up/down or with culmination points).

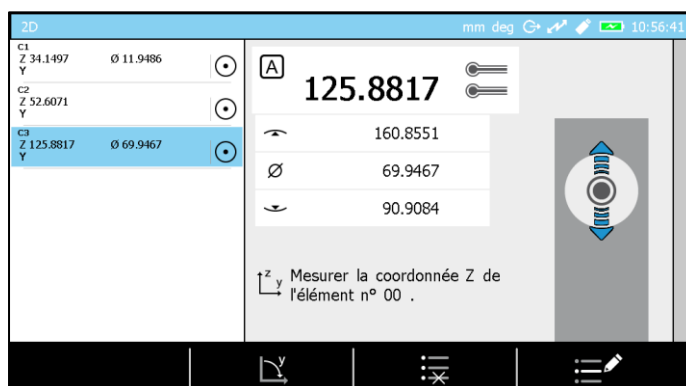

9. Rotate the part in order to position it in an optimal way for the measurement of the second coordinates (in our example it is 90°).

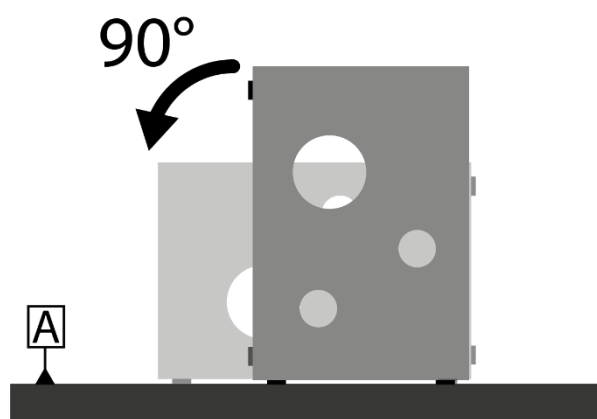

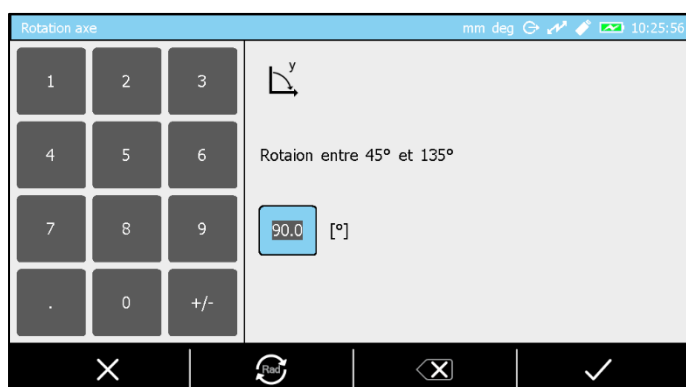

10. Press , insert the rotation angle (90° in our example) and confirm.

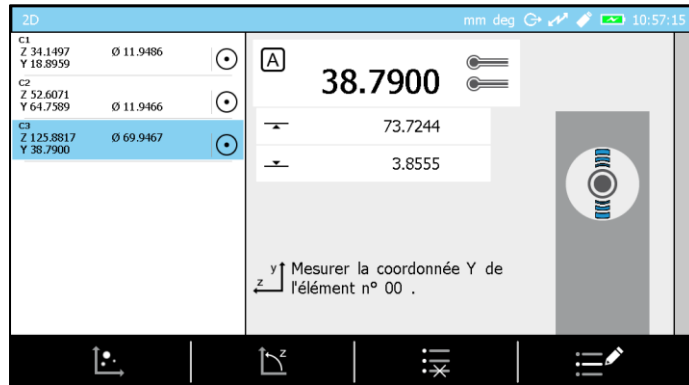

11. Start the measurement of the second coordinates in a similar sequence as the one followed to measure Z coordinates.



12. Rough data are now measured

 **It is always possible to continue to add rough data going from a coordinate to another via the  and  actions.**

If rough data measurement process is over, it is possible to go to the values display and analysis page using .

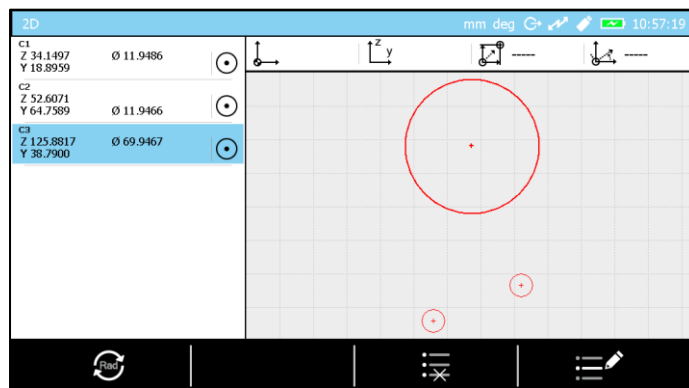

18.6 Results analysis

The software page dedicated to data analysis is split into several zones:

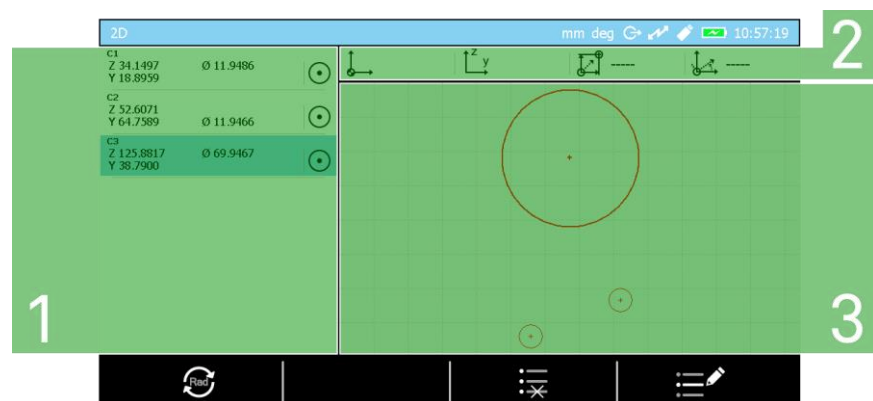

| N° | Description |
|----|------------------------------------------------------------------------------------------------------------------------------------------------------------------------------------------------------------------|
| 1 | Measurements list <ul style="list-style-type: none"> • Rough data blocks • Calculation blocks |
| 2 | Current datum <ul style="list-style-type: none"> • Block used as origin • Block used as Y or Z axis reference • Origin translation value • Datum rotation value |
| 3 | Graph that represents the coordinate system as well as all calculated and measured elements |

18.7 To define a datum

Once rough data are known, the first step consists in setting a datum. For this explanation we will continue with our previous example.

1. Select one of the rough data blocks (C1 for instance). For this, you can either click on the wanted block from the touch screen or use the keyboard arrows buttons.

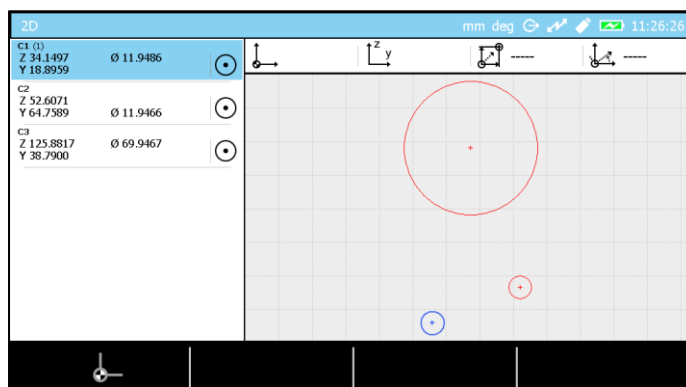

Selecting a bloc (blue rectangle) implies the corresponding element becomes blue in the graph. Note that the selected block has a (1) next to its name.

The available options (linked to the selected blocks) are displayed in the bottom screen bar. In our example, when a unique point or a circle is being selected, only this option is available. It is the option that allows to set a point or the centre of a circle as reference/origin.

2. Press

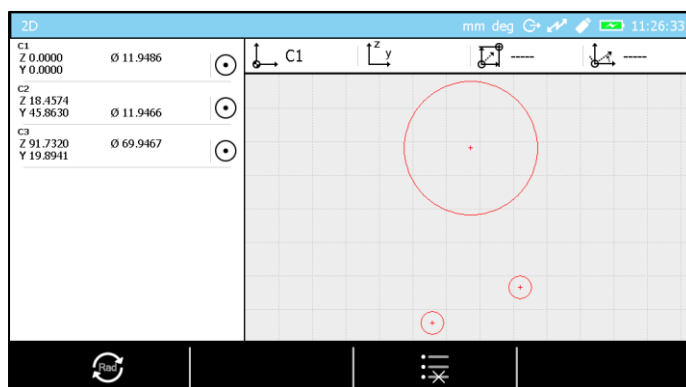

All coordinates have been modified according to the new origin that we can see in the current datum status bar. C1 is now the new origin.

We consider now that we want to define the line going through C1 and C2 as Y axis reference.

3. Select C1 and C2 blocks.

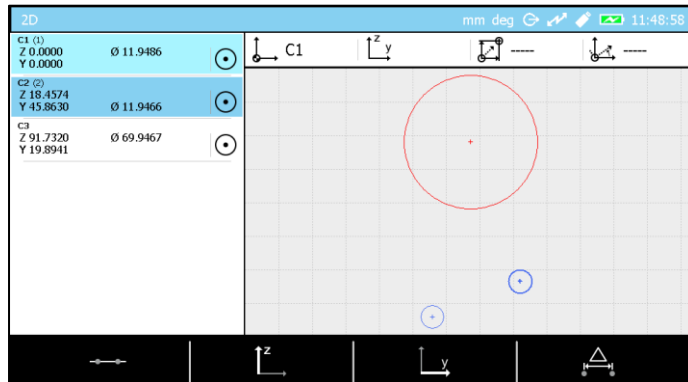

4. Press .

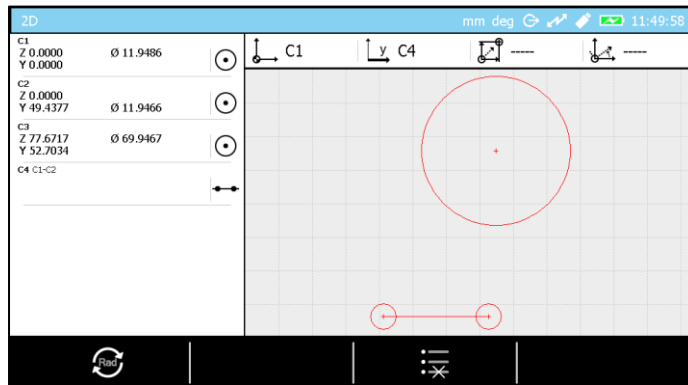

A C4 line is automatically created in the list and set as Y axis reference (visible as well in the current datum status bar).

18.8 Where is the current datum?

If you do not remember where the active datum is located, you can simply check the graphic on the right side of the screen and look for the  icon.

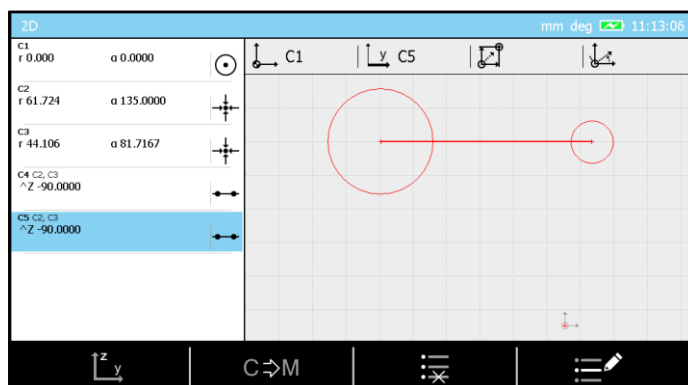

18.9 To change the coordinates system

The 2D mode analysis page allows using two coordinate system types:

- Polar
- Cartesian

You can easily switch from one to the other using the following contextual actions: to switch to polar coordinates and for the Cartesian coordinates.

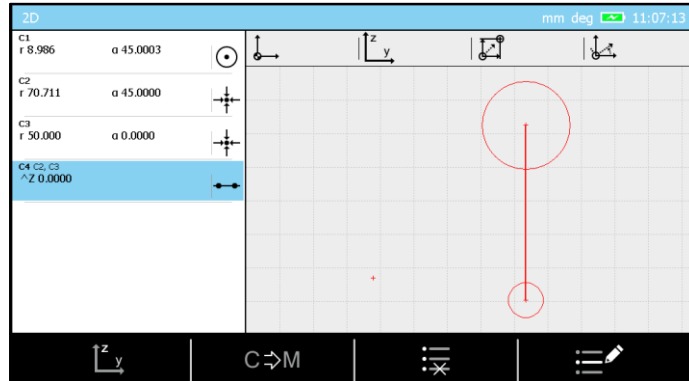

18.10 To define an origin

An origin can be defined when only one block is selected and then using the action. The block can either be a single point or a circle represented by its centre.



18.11 To define a reference axis

A reference axis can be defined with or actions selecting:

- Two points
- Two circles
- A point and a circle
- A line

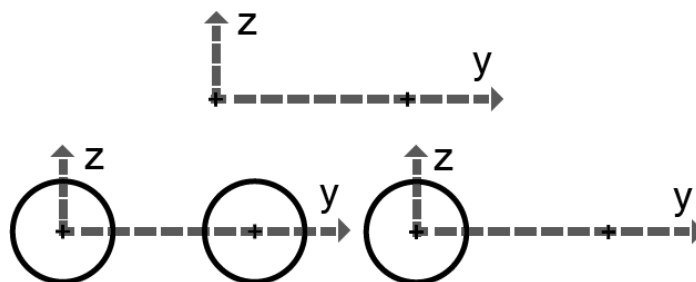

18.12 Midpoint

It is possible to construct a midpoint using the following action from the panel keyboard if the following two blocks are selected:

- Two points
- Two circles
- One point and one circle

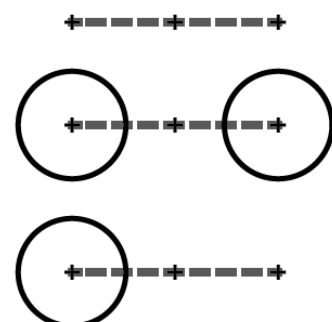

18.13 Intersection of two lines

It is possible to create an intersection point between two lines selecting the following context-based action .

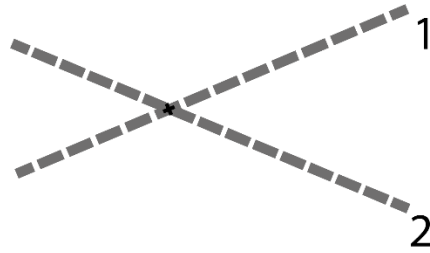

18.14 Line through 2 points

It is possible to construct a perfect line using  action if the following two blocks as selected:

- Two points
- Two circles
- A point and a circle

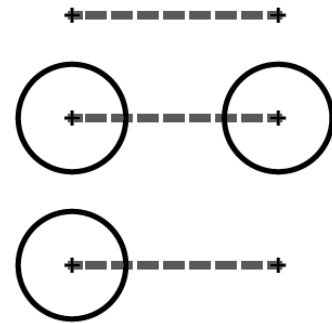

18.15 Bestfit line

A bestfit line is a line being calculated from three blocks (or more) being either points or circles (or a mix of both). This line minimises the D1, D2, D3, D4 et D5 distances (in our below example for instance)

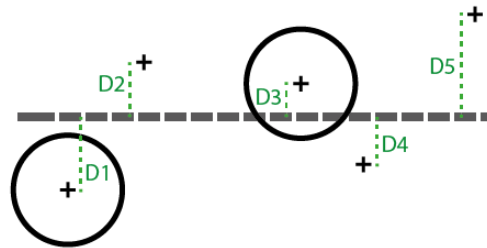

A best fit line can be calculated via the  action.

18.16 Circle through 3 points

It is possible to construct a perfect circle with  action if the following three blocks have been selected:

- Three points
- Three circles
- A combination of three blocks with points and circles

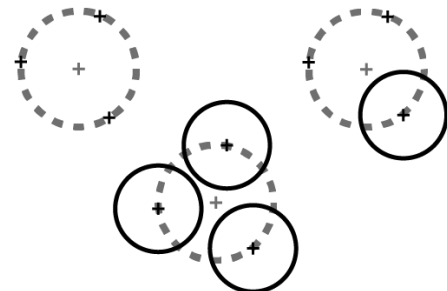

18.17 Bestfit circle

A bestfit circle is a circle calculated from a selection of four blocks (or more). These blocks are either points or circles (or a mix between both). This circle minimises D1, D2, D3, D4 et D5 distances (in our below example for instance).

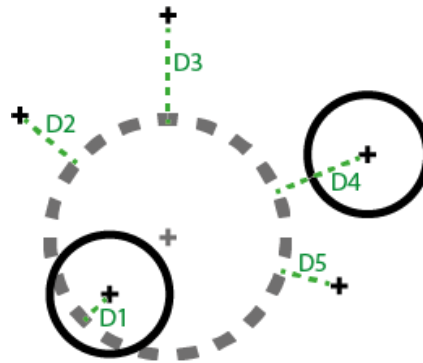

A bestfit circle can be calculated with action.

18.18 Distance between 2 points

It is possible to get the distance between two points, two circles (or a mix between them) using the action.

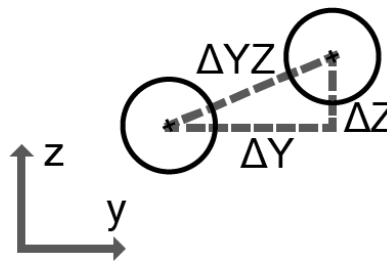

18.19 Angle by 3 points

In order to calculate this angle, it is mandatory to have selected:

- Three points
- Three circles
- A combination of three blocks with points and circles

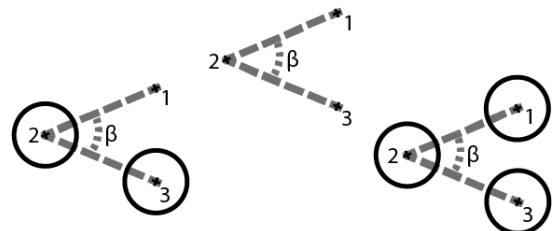

The angle can be calculated with action.



The selection sequence has an impact on the result.

18.20 Angle between two lines

In order to calculate the angle between two lines it is mandatory to select two blocks representing lines and confirm the action with .



The selection sequence has an impact on the result.

18.21 Angle with a datum axis

Sometimes it is important to be able to obtain the angle that a line forms with one of the axes of the current datum. Therefore, you can just create the desired line (see these chapters: line by two points, best fit line) in the measurement history. The created block will always automatically contain the angle that the line forms with the Z axis.



If you want to get the angle that the line forms with the Y axis when running a program, you just have to exit the 2D mode and create a customised function block containing: 90 ° angle with Z-axis.

18.22 Perpendicular distance

The perpendicular distance between a line and a point/circle can be calculated with  option.



18.23 To create a virtual point

It is possible to create a virtual point from the options given in  menu.

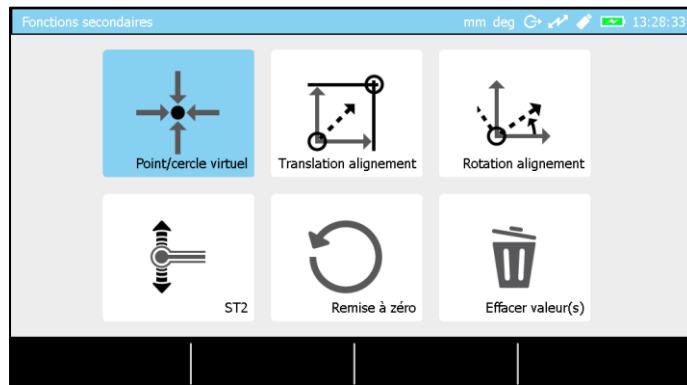

Once entered in this menu and the option selected, the coordinates should be inserted and confirmed in order to create a new block in the measurements list.

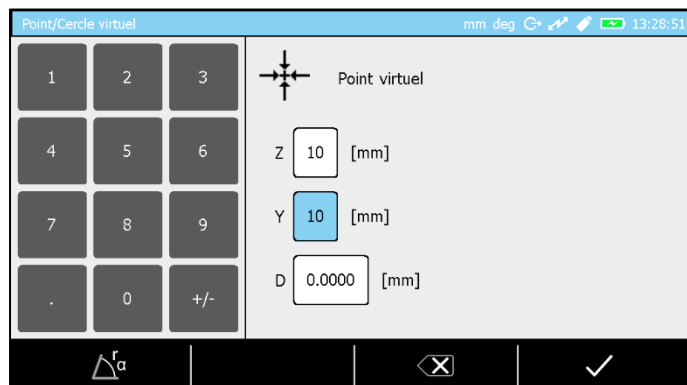

18.24 To create a virtual circle

It is possible to create a virtual circle from the options given in F_x menu.

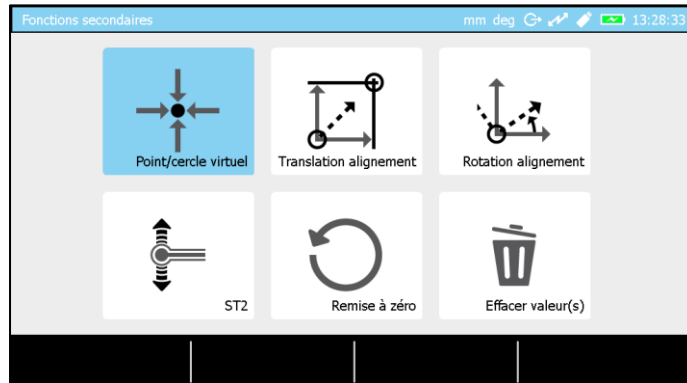

Once entered in the menu and having the option selected, the coordinated of the centre and the diameter of the circle should be inserted and confirmed in order to create a new block in measurements list.

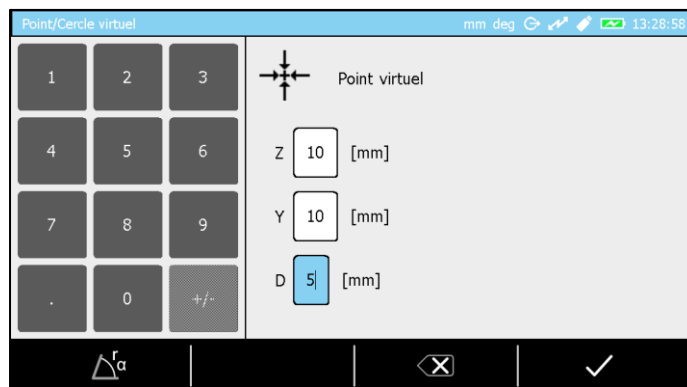

18.25 Origin translation

The coordinates of the current origin can be changed and modified from the options given in F_x menu.

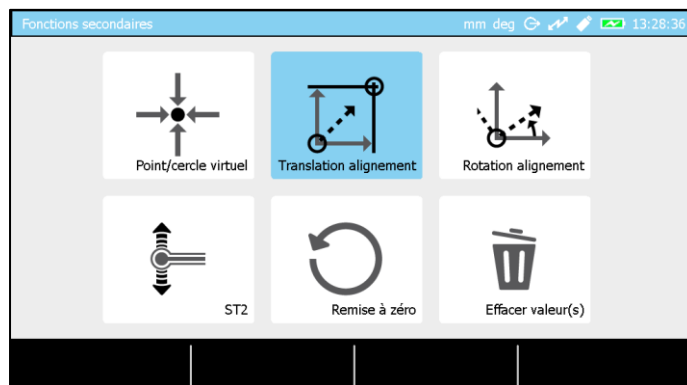

Once entered in the menu and the option selected, the coordinates of the new origin can be inserted and confirmed.

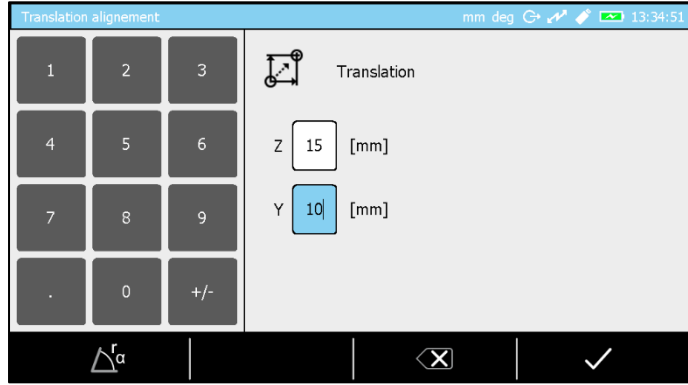

Once confirmed the values are visible at the top of the screen in the current datum status bar.

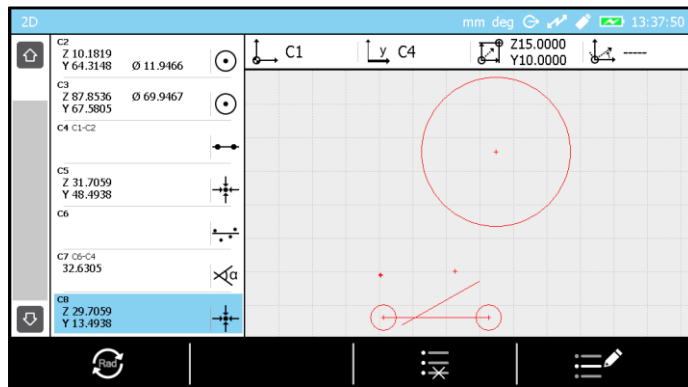

18.26 Datum rotation

The orientation of the current datum can be modified from the options given in **F_x** menu.

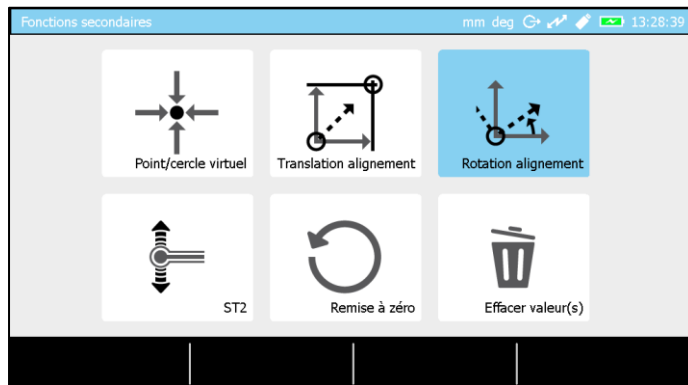

Once entered in the menu and having the option selected, the angle of the rotation can be inserted and validated.

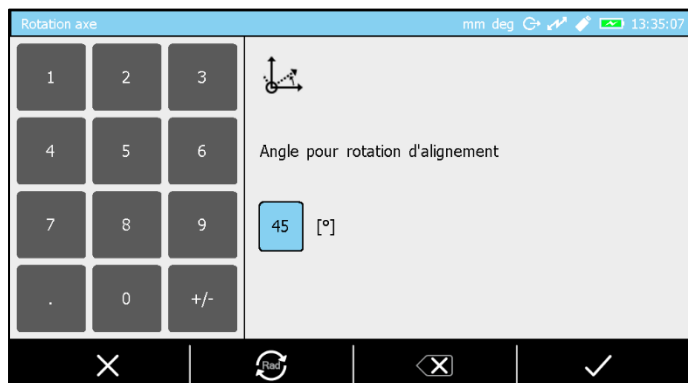

This angle is now visible at the top of the screen, in the current datum status bar.

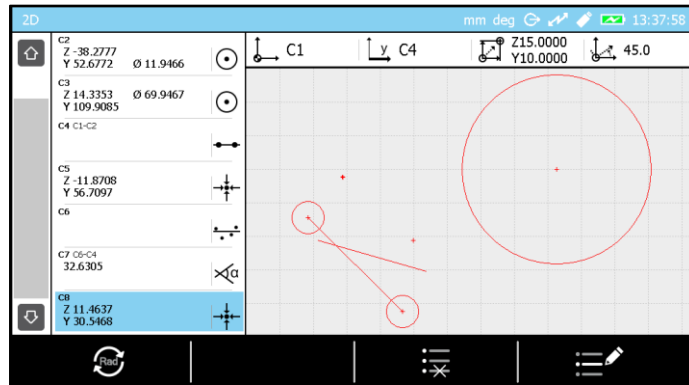

18.27 How do you include a 2D result in a measurement sequence?

As shown previously in this chapter, the access to the 2D mode is exclusively done through the ST2 mode. This means that the 2D mode is included in the ST2 mode (like *Angle* or *Min, max, delta*).

To have the possibility to re-run a 2D calculation sequence later, on another piece, it is necessary to save one or several results taken from the 2D mode, but in the measurements list of the ST2 mode.

The ST2 measurement blocks are globally called M1, M2, M3, M4, ... (M for « measure »). The 2D measurement blocks are globally called C1, C2, C3, ... (C for « circle »).

This is the reason why you can save a 2D result in the ST2 measurements list pressing the context-based action. So, a C block from the 2D mode measurements list becomes a M block in the ST2 mode measurements list.

Here is an example of program creation including results taken from the 2D mode.

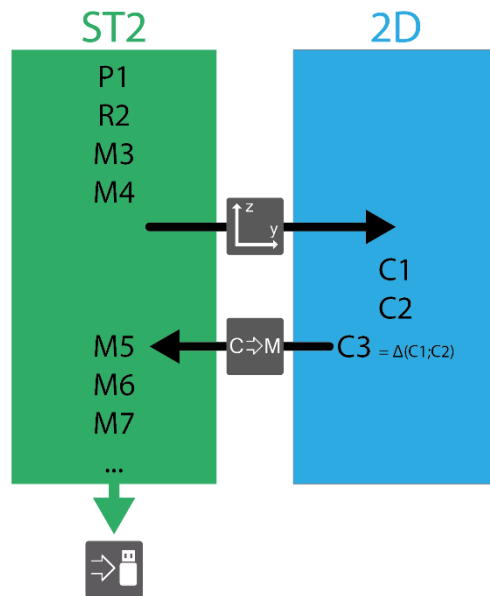

1. Probe calibration to enter ST2 (P1)
2. Reference measurement (R2)
3. Point measurement (M3)
4. Point measurement (M4)
5. Go from ST2 to 2D
6. Z coordinate measurement for two circles
7. Part rotation from a given angle
8. Y coordinate measurement for two circles
9. C1 and C2 are rough data ready to be used
10. Calculation of the distance between both circles (C3)
11. C3 is sent to ST2 and becomes M5
12. Go from 2D to ST2
13. Point measurement (M6)
14. Point measurement (M7) and program is continued
15. Save program in USB stick

The following screenshots quickly describe the previously explained process. We consider that the base principles of St2 (probe calibration, ...) and 2D (rough data measurement, ...) are known.

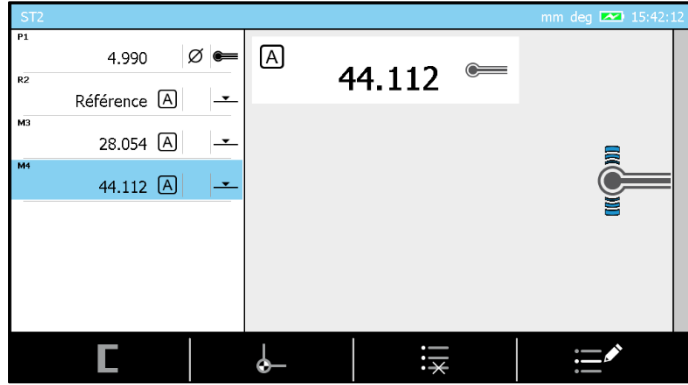

From *ST2* mode where we find already four blocks (probe calibration, reference and two measurements), go to *2D* mode through the F_x secondary functions menu. Once in the *2D* mode measure two circles following the standard process explained earlier in this chapter.

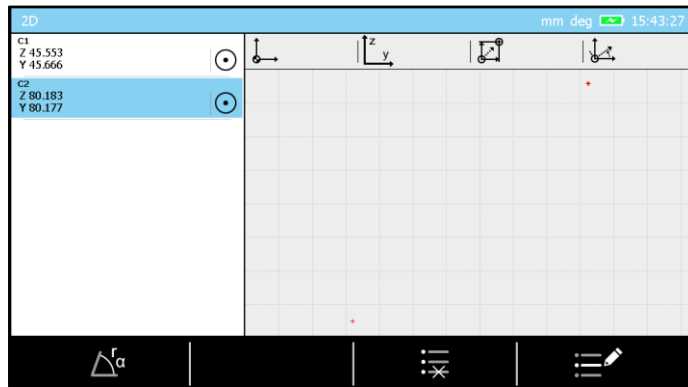

As the two circles have been measured, calculate the distance between their two centres.

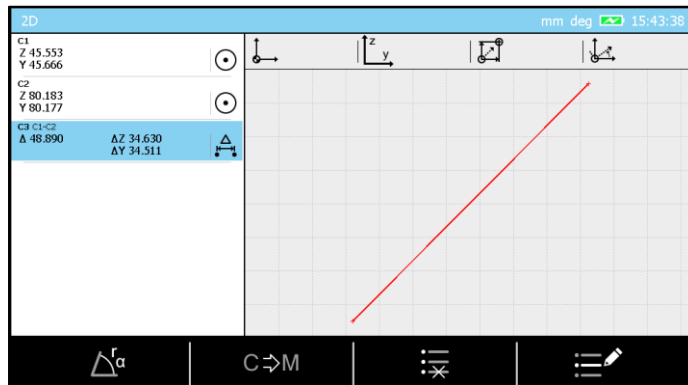

A new *C3* block has been generated in the measurements list. It is now the time to transfer it to the measurements list of *ST2* pressing the $C \rightarrow M$ button. You should hear a beep.

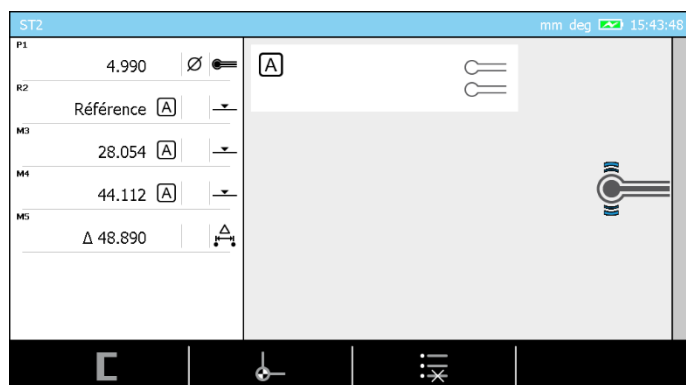

A new M5 block is now created in the ST2 measurements list. This block represents the distance between the two measured circles in the 2D mode. The user can continue to feed the ST2 measurements list continuing the measurement or save the program.



When running the program and the software reaches block number M5, it automatically enters the 2D mode and asks the user to measure the two circles it needs to calculate the M5 distance.

19 DATA MANAGEMENT

19.1 Generality

Your control panel offers the possibility to manage measurement data by sending it to several different peripherals. Each one of these processes is independent from the others. Therefore, each one of the possibilities can be enabled and used at the same time as the others. All combinations are possible. You could for example store your data on a USB key and, at the same time as sending results to a computer via the TLC connector.

 **It is not possible to connect the control panel directly to the local network of a company. The only possible solution is to send data to a computer, which is itself connected to the intranet.**

Data management parameters are accessible via the key  of the main page that you can access at any time by pressing the key  of your control panel.

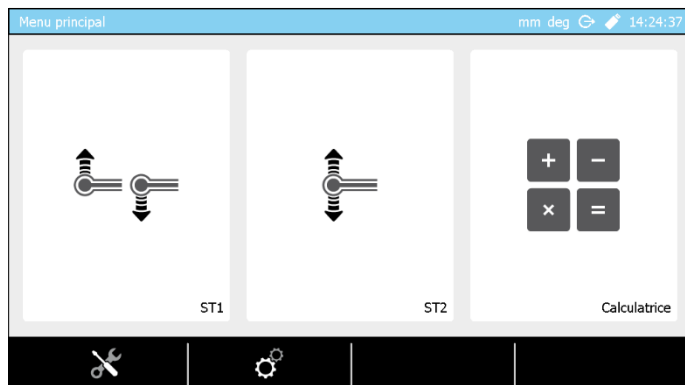

Main page

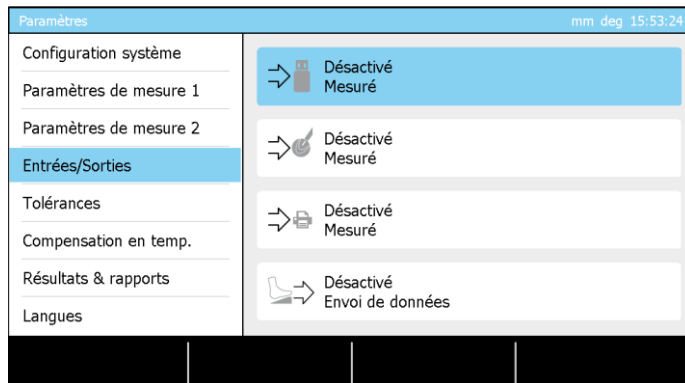

Parameters for data management

19.2 Automatic or manual transmission

Each data management is independent from the others. Therefore, if you choose an option (for example sending data to a USB key), you will have the following possibilities:

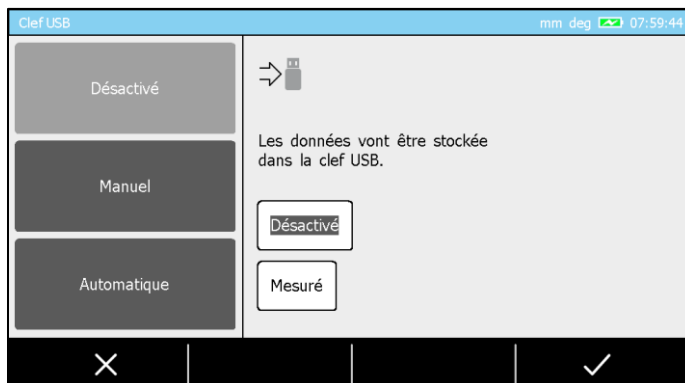

| Option | Description |
|-----------|--------------------------------------------------------------------------------------------------------------------------------------------------------------------------------------|
| Manual | No value will be sent to the selected device unless the user presses the key  of the control panel. |
| Automatic | All measured values entered into the measurement list (last block) are automatically sent to the device. |

When the manual data management option has been selected, it is possible to choose either to send the last block value or, in one batch, all values stored in the measurements list. This is only valid for storing data into the USB key or sending data through the TLC connector.

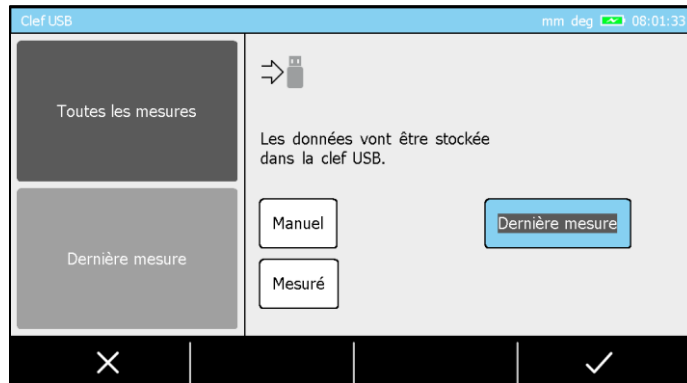

19.3 Transmission format

When you have activated one of the options, it is also possible to define the format in which you would like to receive the data.

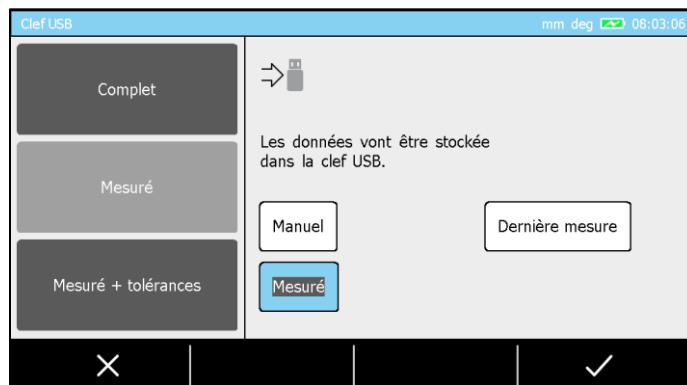

There are currently three available formats:

| Option | Description |
|-----------------------|-----------------------------------------------------------------------------------------------------------------------------------------------------------------------------------------------------------------------------------------------------------------------------------------------------------------------------------------|
| Full | <ul style="list-style-type: none"> • Block number • Editable block name • Block description (example: down probing, ...) • Measured value • Nominal value • Upper tolerance • Lower tolerance • Deviation • Unit • Date • Hour |
| Measured | Only the measured value is sent |
| Measured + tolerances | <ul style="list-style-type: none"> • Measured value • Nominal value • Lower tolerance • Upper tolerance |

19.4 Transmission via TLC (cable)

Sending data via the TLC port to a computer requires the use of a data transmission cable type TLC-USB (TESA reference: 04760181). This cable has a length of 2 meters.



 **The use of such a cable requires the prior installation of a driver on your computer.**

For further information, please refer to the instruction manual provided with the cable or contact your local reseller.

Once the cable is correctly connected at the back of your panel and to your computer, there are several ways to manage the data: by using additional software such as TESA STAT-EXPRESS or TESA DATA-DIRECT or simply by sending the data to your computer via an application type *HyperTerminal*.

For further information, please contact your local reseller.

The connection data is:

| | |
|-----------|------|
| Data rate | 4800 |
| Parity | Even |
| Data bits | 7 |
| Stop bits | 2 |

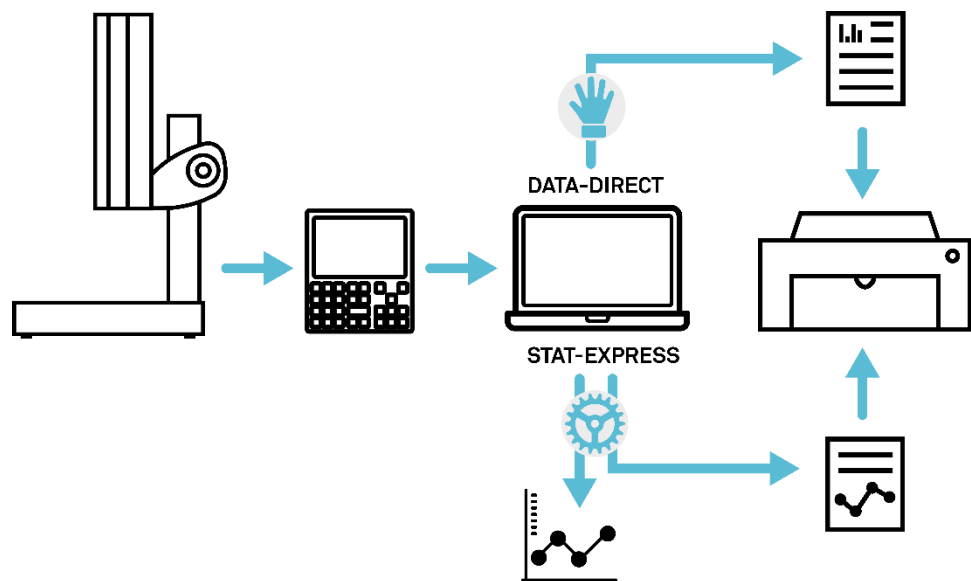

19.5 Transmission via TLC (wireless)

It is also possible to send data to a computer through the TLC wireless connection. To do so, it is necessary to use a TLC cap (TESA reference: 04760180) as well as a TWIN-Station box (TESA reference: 05030012).

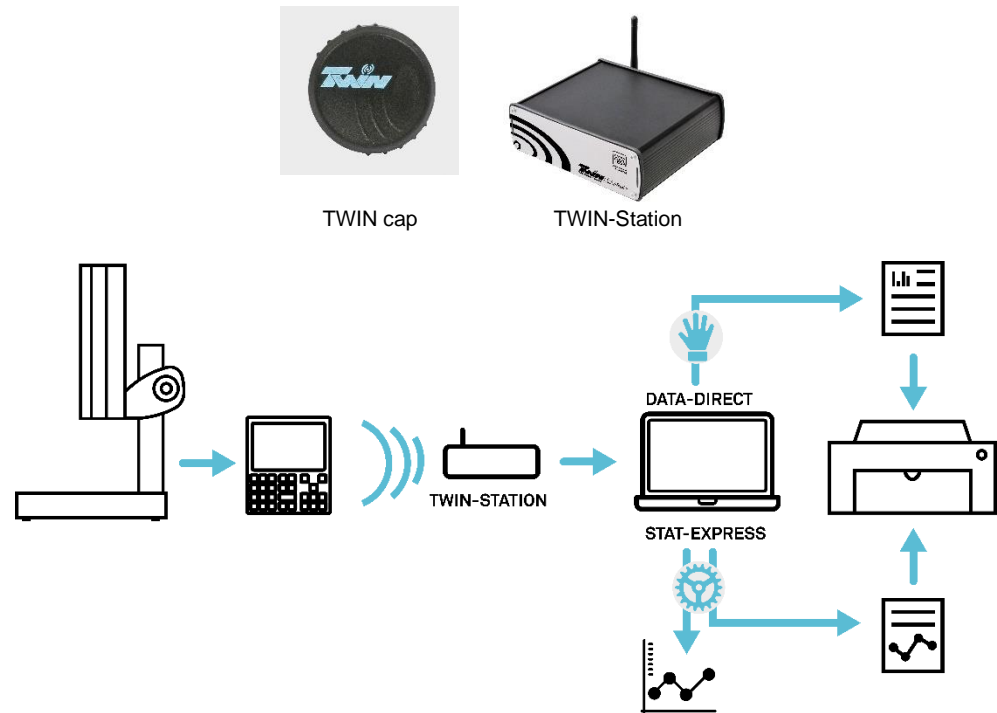

The configuration process of such a system is not described in this document. For more information please read the document related to the wireless communication or contact your local representative.

19.6 Use of the printer

When using the printer, only the “measured” format is available. Hereafter is an example of data be printed:

| | | | | |
|-----|---|---|---|------------|
| R1 | A | | | |
| M2 | A | ⋮ | ↔ | 11.207 mm |
| M3 | A | | ↔ | 23.069 mm |
| M4 | A | △ | ↔ | 23.725 mm |
| M5 | A | | ↔ | -0.656 mm |
| M6 | A | ⋮ | ↔ | 11.211 mm |
| M7 | A | | ↔ | 23.241 mm |
| M8 | A | ∅ | ↔ | 24.059 mm |
| M9 | A | | ↔ | -0.818 mm |
| M10 | A | ⋮ | ↔ | -9.815 mm |
| M11 | A | | ↔ | 0.182 mm |
| M12 | A | | ↔ | 19.992 mm |
| M13 | A | | ↔ | -19.811 mm |
| M14 | A | ⋮ | ↔ | 108.186 mm |
| M15 | A | | ↔ | 119.179 mm |
| M16 | A | △ | ↔ | 21.987 mm |
| M17 | A | | ↔ | 97.193 mm |

19.7 *.pdf report

The μ -HITE has the possibility to generate *.pdf reports on a USB stick connected to its panel. The creation can be:

- automatic after the execution of a measurement programme
- manual when the user selects the action to create the *.pdf file in the contextual action bar

The user can define the process for the report management from the system options menu.

Header

The measurement report has a header containing the following information:

| Kind of information | Note |
|---------------------|------------------------------------------------------------------------------------------------------------------------------------------------------------------------------------------------------------------------------------------------------------------------------------|
| Operator name | Is editable from system options menu |
| Company name | Is editable from system options menu |
| Part name | The program name is re-used as part name |
| Batch name | Is editable from system options menu |
| Date | - |
| Hour | - |
| Company logo | <p>A file called <i>company_logo.jpg</i> that is stored at the root of the USB stick is used.</p> <p>The company logo is not mandatory. If no logo file is detected by the panel when the report is being created, the dedicated zone in the header is automatically adjusted.</p> |

Part picture

It is possible to insert a part picture at the beginning of the measurement report. Like for the company logo in the header, when generating the document, the software checks if a file corresponding to the program exists at the root of the USB stick. If it does, the image will be considered. If it does not, the document will be adjusted consequently.

Please note that the system is flexible. Indeed, it is possible to have several programs stored in the USB stick et for each of them a different image could be used.

To have the panel consider an image when generating a report, it is important that the image file has the same name as the run program. Here are some examples:

| Sequence name | Image name stored at the root of the USB stick |
|----------------|------------------------------------------------|
| Piece_TESA.st1 | Piece_TESA.jpg |
| test123.st2 | test123.jpg |

Report example:

RAPPORT DE MESURE

| | | | | | |
|------------|-------------|-----|---------|-------|------------|
| Opera... | operateur 4 | Nom | exemple | Date | 16/08/2017 |
| Entreprise | TESA SA | Lot | lot 15 | Heure | 17:52 |

| N° | Caractéristiques | Mesuré | Nominale | Tolérance supérieure | Tolérance inférieure | Etat |
|----|------------------|--------|----------|----------------------|----------------------|------|
| M3 | | 28.047 | 28.05 | 0.005 | -0.005 | |
| M4 | | 49.057 | 49.06 | 0.004 | -0.004 | |
| M5 | | 9.891 | 9.9 | 0.006 | -0.006 | |
| M6 | | 28.053 | 28.05 | 0.008 | -0.008 | |
| M7 | | 70.056 | 70.06 | 0.009 | -0.009 | |
| M8 | | 49.052 | 49.06 | 0.01 | -0.01 | |

voire partenaire de métrologie
1/1

19.8 Annotate your measurement program





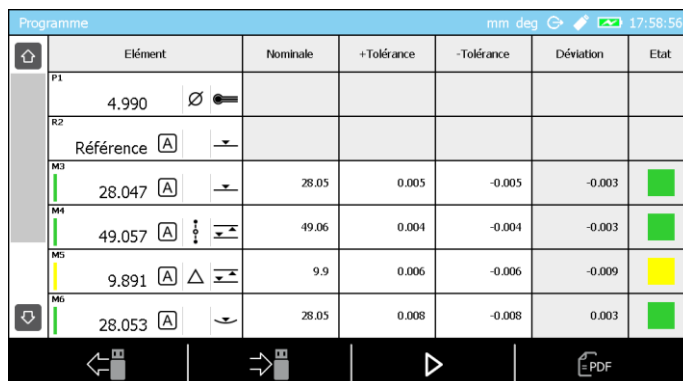













When running a measurement program created by a third person, it is often convenient to be able to rely on explanations or notes made by this person. To do so, it is possible to create on the USB key a document in *.pdf format describing the program currently stored on the panel and giving the possibility to annotate each of the measurement blocks of that program.

It is possible to generate this document on a USB key from the program management screen.



Simply press the contextual action corresponding to the *.pdf document to generate the document on the USB key.

Sample annotation document:

| PROGRAMME DE MESURE | |
|----------------------------------------------------------------------------------------------------------------------------------------------------------------------------------------------------------------------------------------------------------------------------------|------|
| Bloc | Note |
| P1 4.990   | |
| R2 Référence   | |
| M3 28.054   | |
| M4 49.063    | |
| M5 9.902    | |
| M6 28.052   | |
| M7 70.060   | |
| M8 (M3 + M7) / 2 49.057    | |

1/1

19.9 Screenshot

In order to simplify the creation of personalised procedures, sharing knowledge and training employees, it is possible to take a screenshot at any time.

It is necessary to connect a USB key at the rear of the control panel and to maintain the key  pressed for approximately 3 seconds until a validation beep is generated.



It is possible that the control panel does not detect the USB key if the time between the connection of the key to the panel and the screenshot is too short. The panel needs a few seconds in order to recognise that an USB key has been connected.

20 PROGRAM MANAGEMENT

20.1 Introduction

Because beyond the simple measurement of a unique part there is often the need to control a batch of pieces that could be either small or big, TESA developed a learning mode that gives the mean to manage in a simple way measuring sequences. Once the program has been run, general information of the piece status is automatically displayed on the panel screen.

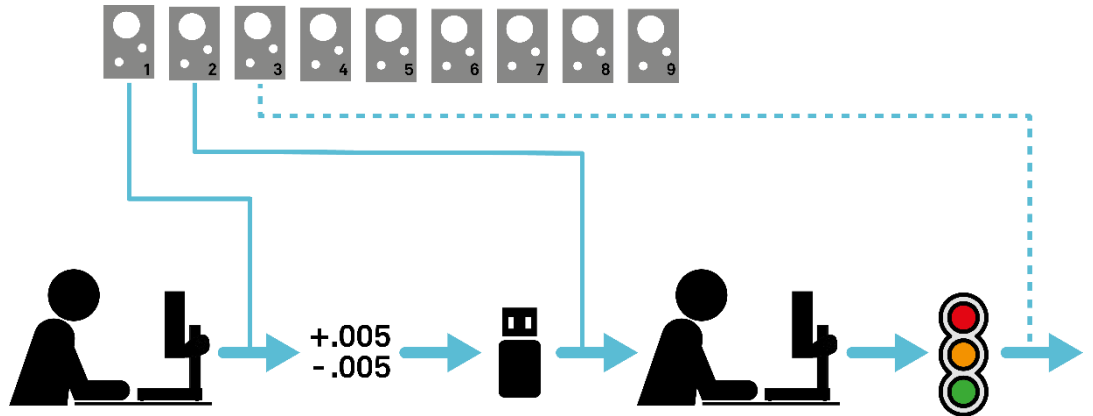

20.2 Program creation

The programming principle by learning means the creation of a measuring sequence on an arbitrary piece (from a batch or not). These measuring sequences can be realised either from ST1 or ST2 mode.

The part that is used to create the measuring sequence is not to be considered as reference part. It is only the mean to define the steps of the sequence by measuring feature after feature on it.

In fact, each block from the measurements list corresponds to a step of the measuring sequence that can be executed later. This means that all measurements list corresponds to a potential measuring sequence.

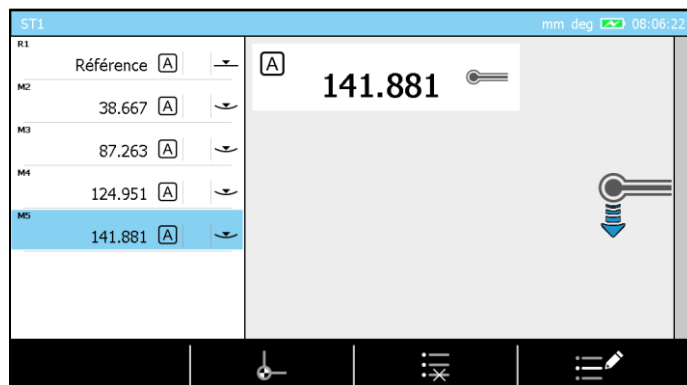

For instance, this memory of 5 blocks defines a 5-step measuring sequence.

20.3 Insert tolerances





The tolerance management implies that measurement blocks are in memory. Without blocks, it is not possible to insert tolerances.

Once the sequence has been done in ST1/ST2, press button from panel keyboard.

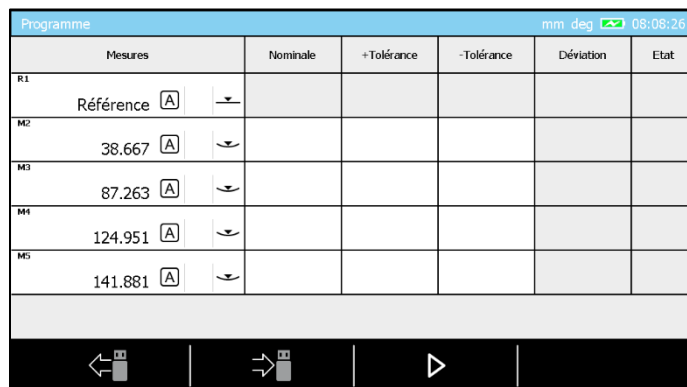

You have now the possibility to choose the option concerning programs management.



| Mesures | Nominale | +Tolérance | -Tolérance | Déviation | Etat |
|---------------------------------------------------------------------------------------------------|----------|------------|------------|-----------|------|
| R1 Référence  | | | | | |
| M2 38.667  | | | | | |
| M3 87.263  | | | | | |
| M4 124.951  | | | | | |
| M5 141.881  | | | | | |

The displayed page corresponds to a blocks' list equivalent to the one in memory. With this sequence global view, it is now possible to proceed to the tolerancing for all dimensions to be controlled.

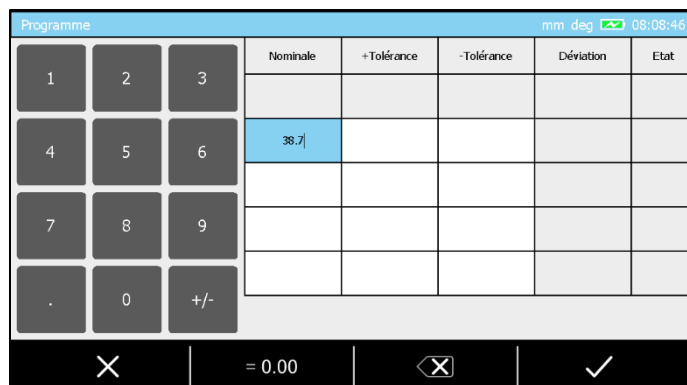

| | | | Nominale | +Tolérance | -Tolérance | Déviation | Etat |
|---|---|-----|----------|------------|------------|-----------|------|
| 1 | 2 | 3 | | | | | |
| 4 | 5 | 6 | 38.7 | | | | |
| 7 | 8 | 9 | | | | | |
| . | 0 | +/- | | | | | |

Inserting a value for this is possible:

- Clicking on the wished square (touch-screen) and enter the value using the panel keyboard
- Double clicking (touch-screen) on the wished square and using the numerical keyboard displayed on the screen
- Selecting the wished square with the keyboard arrows and displaying the numerical virtual keyboard on the screen confirming the selection with .

| Mesures | | Nominale | +Tolérance | -Tolérance | Déviaton | Etat |
|---------|---------------|----------|------------|------------|----------|------|
| R1 | Référence [A] | | | | | |
| M2 | 38.667 [A] | 38.700 | 0.500 | -0.500 | -0.033 | ■ |
| M3 | 87.263 [A] | 87.300 | 0.500 | -0.500 | -0.037 | ■ |
| M4 | 124.951 [A] | 125.000 | 0.500 | -0.500 | -0.049 | ■ |
| M5 | 141.881 [A] | 141.900 | 0.500 | -0.500 | -0.019 | ■ |

20.4 Tolerancing with ISO table

In order to use the ISO table to set tolerances it is mandatory to be located in the page dedicated to tolerances insertion.

| Mesures | Nominale | +Tolérance | -Tolérance | Déviaton | Etat |
|------------------|----------|------------|------------|----------|------|
| F1 2.845 | | | | | |
| R2 Référence [A] | | | | | |
| M3 140.830 [A] | | | | | |
| M4 19.902 [A] | 19.900 | | | 0.002 | |









Once a nominal value for a diameter has been confirmed, the button is automatically displayed at the bottom of the screen. It allows accessing the following table.

| | 6 | 7 | 8 | 9 | 10 | 11 | 12 | 13 |
|----|---|---|---|---|----|----|----|----|
| D | | | | | | | | |
| E | | | | | | | | |
| F | | | | | | | | |
| G | | | | | | | | |
| H | | | | | | | | |
| JS | | | | | | | | |

It means now only to select the wished tolerance and confirm it in order to load automatically the values for the given characteristic.

20.5 To save a sequence

Once your sequence has been correctly done you can save it into your USB stick. For this, press button from the panel keyboard then select programs management option.

| Mesures | | Nominale | +Tolérance | -Tolérance | Déviaton | Etat |
|---------|---------------------------------------------------------------------------------------------|----------|------------|------------|----------|-------------------------------------------------------------------------------------|
| R1 | Référence  | | | | | |
| M2 | 38.667  | 38.700 | 0.500 | -0.500 | -0.033 |  |
| M3 | 87.263  | 87.300 | 0.500 | -0.500 | -0.037 |  |
| M4 | 124.951  | 125.000 | 0.500 | -0.500 | -0.049 |  |
| M5 | 141.881  | 141.900 | 0.500 | -0.500 | -0.019 |  |

This page will be displayed. It is now possible to insert tolerances (but not mandatory) then to save the sequence pressing . the next step is to enter the program name and confirm it to end the process and save the data in the USB stick.





 A sequence that has been done in ST1 mode will be saved with *.st1 format. It is the same for ST2. For this case the *.st2 format will be used.



 At the top right of the screen, you can find the number of characters which are still available to define the program name.

20.6 Sequence loading

Loading a measurement sequence from USB stick does not imply that it will be automatically run. Indeed, the loading only recalls the sequence and places it in corresponding memory (ST1 or ST2).

 The blocks from the memory are automatically overwritten when loading a program from the USB stick. It is not possible to get these blocks back.

A sequence can be recalled whenever from ST1 or ST2 mode pressing  from control panel then selecting the programs management option.

 Prior to load a ST 2 sequence from your USB stick, it is not mandatory to have your probe being calibrated. You can directly access the program management options from the probe calibration page pressing  button.

| Mesures | | Nominale | +Tolérance | -Tolérance | Déviaton | Etat |
|---------|-----------|----------|------------|------------|----------|------|
| R1 | Référence | | | | | |
| M2 | 38.667 | 38.700 | 0.500 | -0.500 | -0.033 | |
| M3 | 87.263 | 87.300 | 0.500 | -0.500 | -0.037 | |
| M4 | 124.951 | 125.000 | 0.500 | -0.500 | -0.049 | |
| M5 | 141.881 | 141.900 | 0.500 | -0.500 | -0.019 | |

Once this page is being displayed, press , select the wanted program from the list and confirm your selection.

| Sélection de fichier | |
|----------------------|---------------------------------------|
| Programme 1 | Sélectionner un fichier et presser . |
| Programme 2 | |
| Programme 3 | |

When recalling a program, you will have access to a programs' list corresponding to the sequences saved into your USB stick. If you want to recall a program from ST1 mode, the list will only show programs with *.st1 format. It is the same recalling a *.st2 sequence from ST2 mode.

Once a sequence has been loaded in memory, it can be either modified or run in loop.

20.7 To run a sequence

Running a sequence requires blocks in memory. These blocks can either come from a program that would have been loaded from your USB stick or simply from measurements performed without any prior saving.

Once you are sure your program in memory is the one you want, press button from panel keyboard and select the programs management option.

| Mesures | | Nominale | +Tolérance | -Tolérance | Déviaton | Etat |
|---------|-----------|----------|------------|------------|----------|------|
| R1 | Référence | | | | | |
| M2 | 38.667 | 38.700 | 0.500 | -0.500 | -0.033 | |
| M3 | 87.263 | 87.300 | 0.500 | -0.500 | -0.037 | |
| M4 | 124.951 | 125.000 | 0.500 | -0.500 | -0.049 | |
| M5 | 141.881 | 141.900 | 0.500 | -0.500 | -0.019 | |

Insert tolerances if needed and start the process pressing .

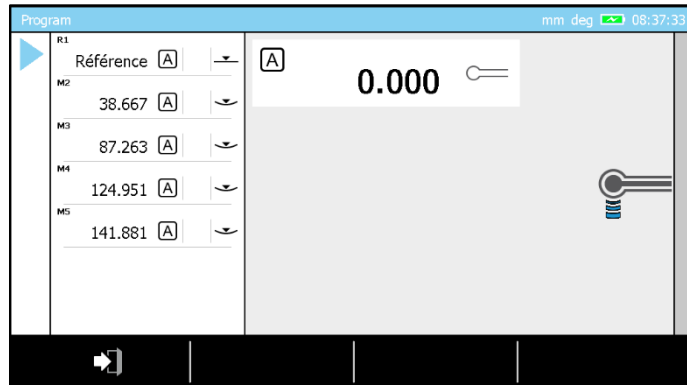

When running a sequence a play icon is displayed on the left of the screen. It represents the current measurement step in the program and inform the user of the block that is currently run.

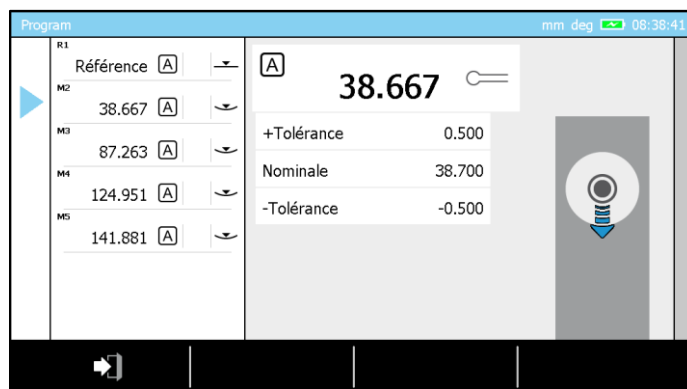

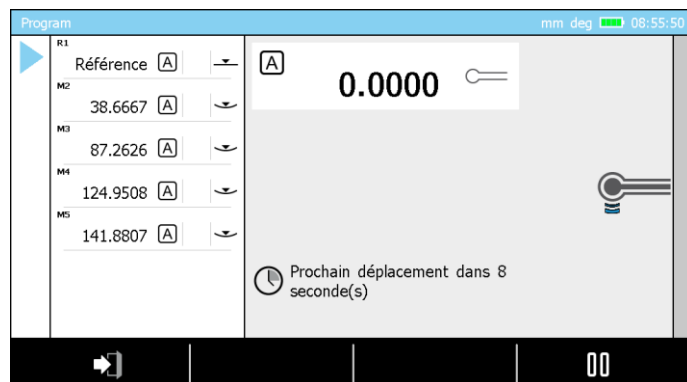

A time countdown is also displayed (the time is editable from system options menu). It is the mean to know the remaining time before the next probe displacement and let the user avoid any crash of the probe with the part to be measured.



20.8 To pause a sequence run

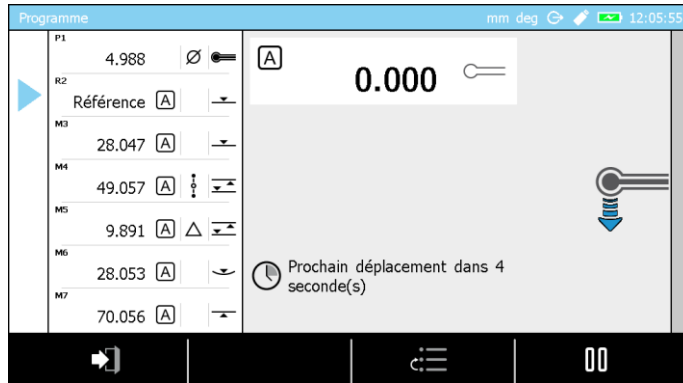

When the sequence is running, it is possible at any time to pause it pressing the  context-based action.

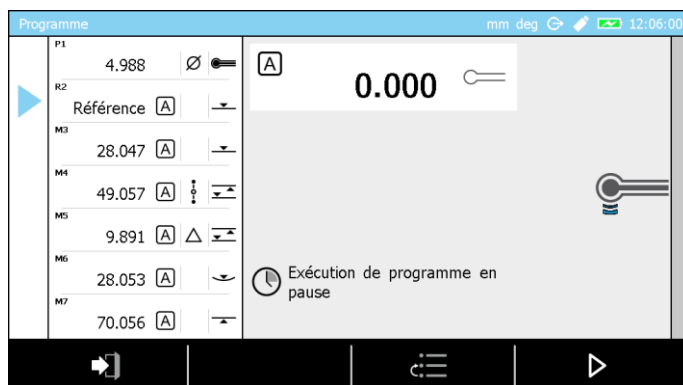

Once the sequence run has been paused, it is possible to continue the run pressing the  context-based action.



20.9 To re-measure a block

When running a measurement sequence, it is not uncommon to wish to re-measure the dimension that has just been measured. This is possible by pressing on the  context-based action. The light blue cursor  will then reposition on the previous block to allow its re-measurement.



It is possible to go several blocks back by repeatedly pressing the context-based action .

20.10 Timer

When running a measurement sequence, it is important to give the operator time to position the probe, so that it does not strike the workpiece when moving to the next measurement zone.

To do so, the operator can enter the desired number of seconds before moving the key in the system options menu.

This timer will be used before moving to a measurement zone or before any measurement.

If the user inserts the value 0 as a timer value, he must manually confirm the movement to the next block in the entire measurement sequence by pressing the  action.

Below, you can find a sample sequence to understand the sequence recall moments during which the countdown will be used.



1

The probe is inserted in the groove manually moving the piece or the instrument

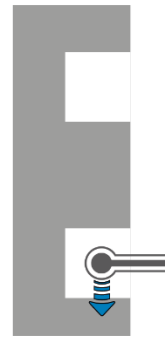

2

A measure is taken. This will start the timer for the next probe displacement to the next measurement zone

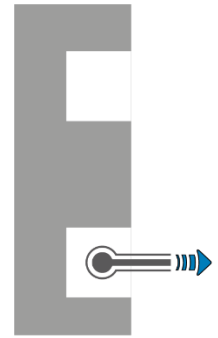

3

While in countdown, the operator has time to disengage the probe from the part to avoid any collision when being moved to go to the next measurement area



4

The countdown is finished, the probe moves automatically to the next area

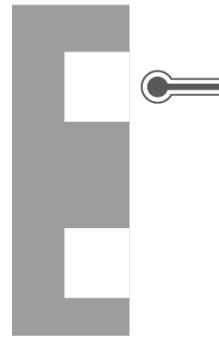

5

The probe position is now stabilised at a height which is close to the point to measure, a new countdown is started

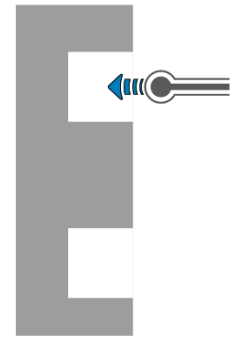

6

While in countdown, the operator has the time to position the probe correctly in the element he wants to measure



7

The probe is now well positioned, the countdown is not finished

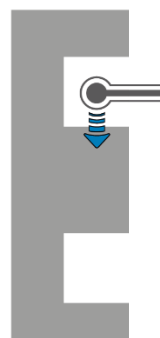

8

When reaching 0, the probe goes down to take the point



If the distance between two measurements is small enough, do not waste any time, one only countdown will be used.

20.11 Results

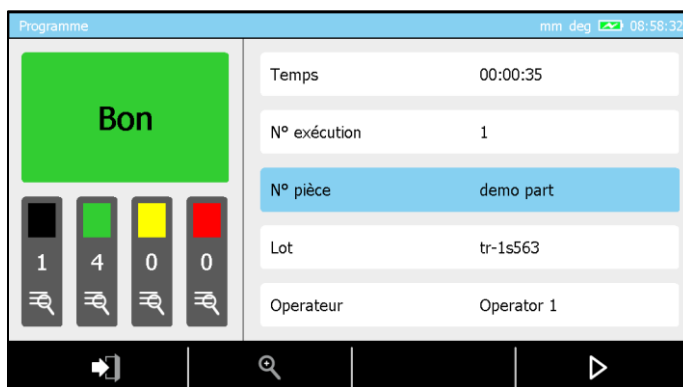

Once you have run a sequence and reached the end of it, a result page is automatically displayed.



You'll find in the page:

- Part status
 - Good
 - Not good
 - Program end (if the sequence does not include any tolerances)
- The number of
 - Total measurements in black
 - Values in tolerances in green
 - Values to be reworked in yellow
 - Values out of tolerances in red
- Run time
- Run number
- Part name (corresponding to program name)
- Batch name
- Operator name

It is possible to filter the result values by status. To do so, press one of the  button. It will display only the corresponding values having the same status (all good, all bad or all having to be reworked).

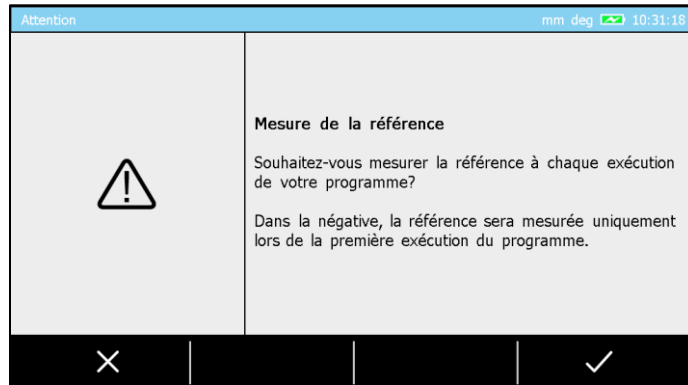

| | |
|---------------------------------------------------------------------|-------------------------------------------------------------------------------------------------------------------------------------------------------------------------------------------------------------------------------------------------------------------------------------------------------------------------------------------------------------------------------------------------------------------------------------------------------------------------|
| 20.12 To run a sequence in loop | Once the end of a sequence run is reached, the global results page is displayed. You can either re-run the same sequence from this page using  option or exit the process with  . |
| 20.13 Probe calibration block & run the sequence in loop | A sequence that has been done from ST2 mode will, most of the time, include a probe calibration block as first block. When running a sequence having such block as first one (if there's no other probe calibration block in the same sequence) running the sequence for the second time will imply that the calibration block won't be taken into account. |
| 20.14 Reference block & run the sequence in loop | If a measurement sequence takes only one reference (a single reference block) into account during its execution, the software will offer you two ways to manage it: <ul style="list-style-type: none"> • Measuring the reference at each run of the sequence • Measuring the reference only at the first sequence run. This reference is kept in memory for future executions (under the condition of not leaving the sequence execution mode). |



21 CONTROL AND UPDATE

21.1 Generalities

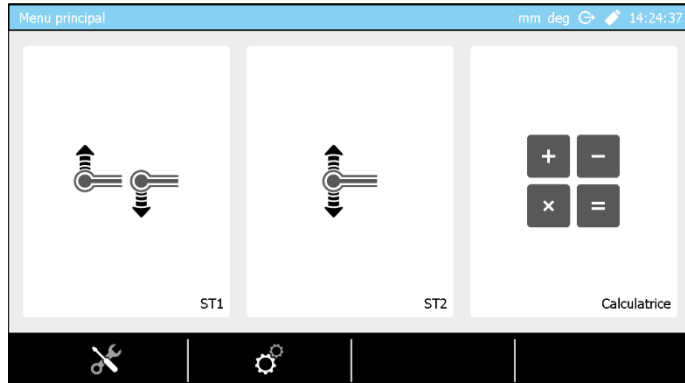

As a user, you have the possibility to access certain options that enable a quick control of analysis of your system.

The control options are available in the service menu via the contextual action  available on the main page of the software that you can access at any time by pressing the key  of your control panel.

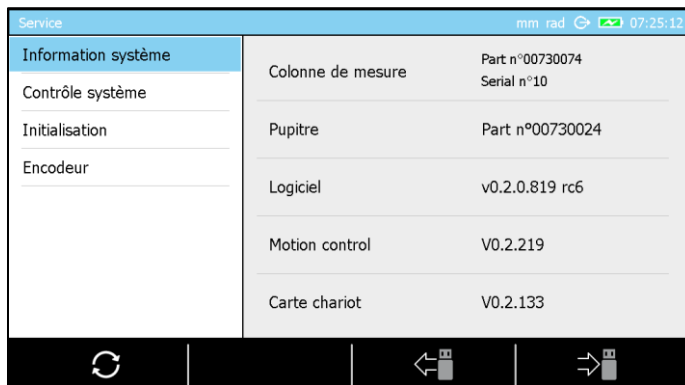

21.2 System information



The first tab of the mode gives you an overview of the configuration of your height gauge. You can get the configuration information of your height gauge by pressing the button . A text file that represents the current configuration will be created on your USB key. This configuration can be loaded onto the panel later from the USB key via the button .

 **When the system options have to be modified according to certain types of applications, it is an advantage to be able to recall a configuration previously stored on a USB key, so that you do not have to manually modify the parameters.**

21.3 Control of the system

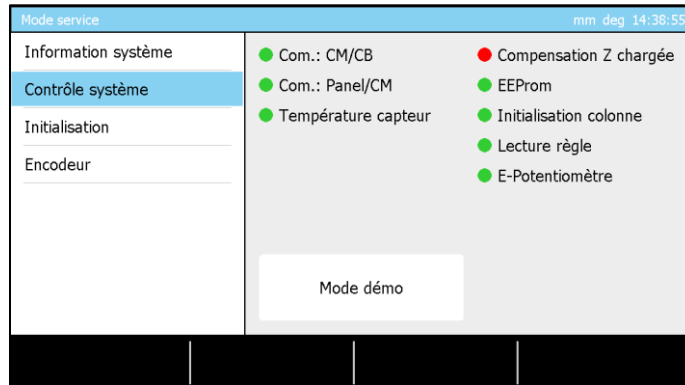

This page of the software enables the visualisation of certain crucial parameters of the system in order to quickly determine the status of the instrument.

21.4 Sensor control

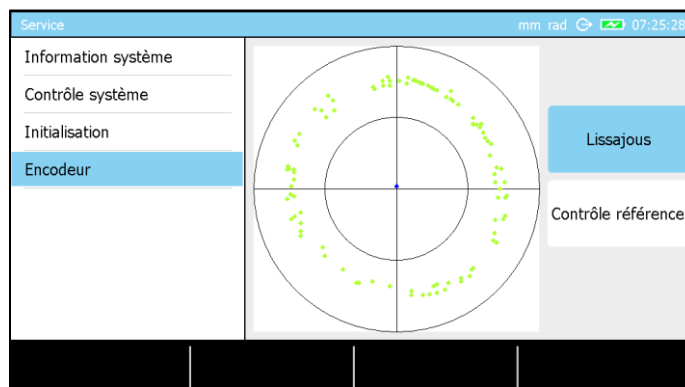

In order to verify the sensor and its positioning regarding the measurement scale, make sure to activate the option “Lissajous” on the right side of the screen. You should then see a circle appear on the screen, as shown in the above picture. In order to control the sensor of your instrument, you only have to move your probe slowly up or down (avoid moving to the end stop), which will lead to the display of green points on the screen. A sensor has been correctly configured when you see a centred circle appearing.

21.5 Reference mark control

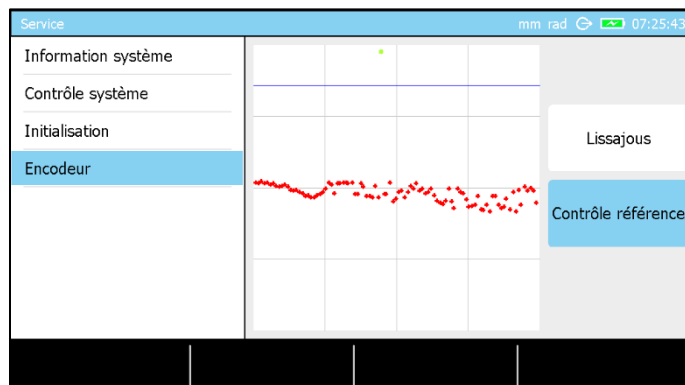

On this page, the option “reference control” has to be activated first. Then slowly move the probe up or down. It is the same principle as the initialisation of the height gauge when turning on the instrument. The encoder has to pass in front of the control mark defined on the scale (at a height of approximately 15 cm from the base). If the mark is detected, a beep is generated and a green point is displayed on the screen.

21.6 Software update

For the following procedure it is supposed that you already have the file that corresponds to the software version that you would like to load onto your instrument. If you do not have this file, please contact your local reseller.

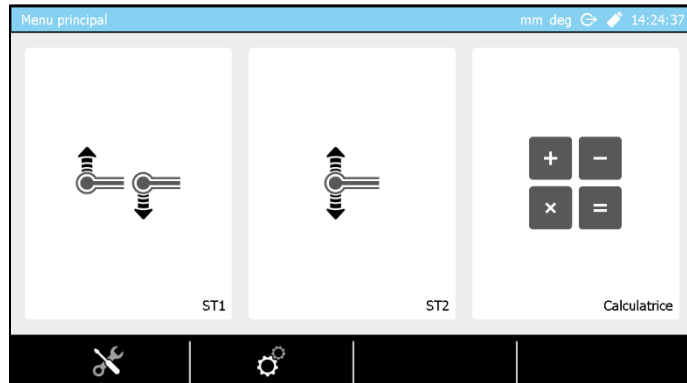

1. Press the key  in order to go to the main page of the software.

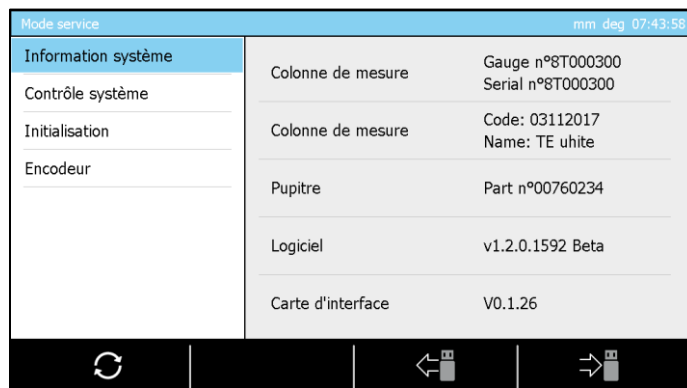

2. Enter the service mode by clicking on the contextual option .



3. Make sure to be on the first page of the mode and to have access to the following option at the bottom of the screen . Click on it.

4. A warning message will automatically display, press on  in order to continue the process or  in order to cancel it. If the process is not cancelled, the software will automatically close the application and open a special service mode.

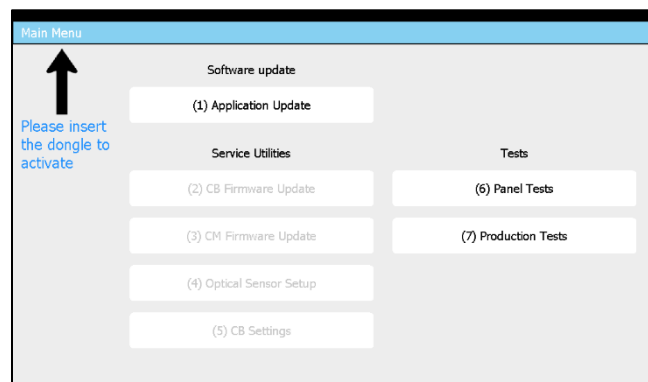

5. Make sure that the software file has correctly been copied to the root folder on the USB key that you now have to connect to your control panel.
6. Press the button "1" of the numerical keyboard or click on option "Application Update" on the screen.

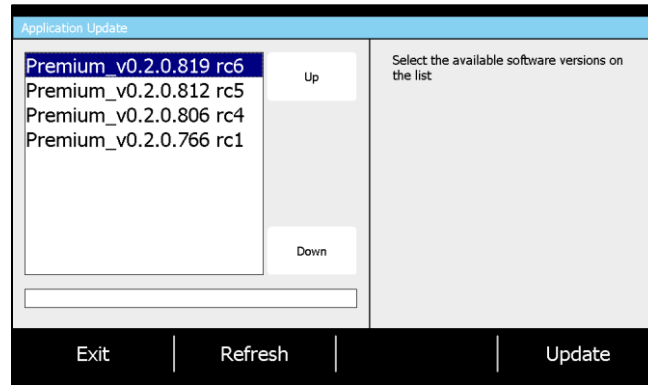

The software will list all available versions on your USB key and displays them in chronological order with the most recent one at top of the list. In the case above, the USB key contains 4 different software versions.



















7. Once you have chosen your version, click on the button “Update”. The software will be installed (this can take several minutes) and then warn you that the control panel will automatically shut down.
8. Wait until the control panel is automatically turned off then manually turn it on again.
9. You can now use your height gauge.











Each software version (loaded onto your control panel) is linked to firmware versions used in the electronic cards that are part of your instrument. When you update your instrument with a new software version, make sure that the electronic cards do not have to be updated as well, by contacting your local reseller.







22 CONTEXTUAL ACTIONS

22.1 General actions

| Definition | |
|-------------------------------------------------------------------------------------|----------------------------------------------------------------------------------------------------------------------------|
|  | Cancel Allows you to cancel the current process or to leave a mode without saving any changes. |
|  | Delete Allows you to delete the selected value. |
|  | Return Allow to come back to the previous page |
|  | Cartesian coordinates Allows to work in Cartesian coordinates. |
| Deg | Change angle unit Allows you to change the unit of the displayed angles. The new unit is "degree". |
|  | Delete value or letter Allows you to delete the last character entered when manually entering a name or a value. |
| DMS | Change angle unit Allows you to change the unit of the displayed angles. The new unit is "degree:minute:second". |
|  | Validate Allows you to validate the current process or to leave a mode while saving any changes. |
|  | Edit Allows you to edit the name of a selected measurement block in the memory. |
|  | Pause Allows you to pause the active process |
|  | Execution Allows you to start a measurement process or restart it in case it was paused before. |
|  | Polar coordinates Allows you to work in polar coordinates. |
|  | Change graph Allows you to change the type of graph displayed when measuring culmination points. |
| Rad | Change angle unit Allows you to change the unit of the displayed angles. The new unit is the "radian". |
|  | Recall Allows you to recall a file from the USB key. |
|  | Cancel last measurement Allows you to carry out the last measurement in the memory again. |
|  | Save Allows you to save on the USB key. |
| = 0.00 | Zero setting Allows you to quickly set the selected value to zero. |
|  | Ignore Allows you to avoid certain steps of procedures and to directly access the result. |
|  | Delete block Allows you to delete the last block of the measurement memory. |
|  | Utility services Access to the menu for maintenance of the height gauge as well as access to its information. |
|  | Update Starting update of the selected option. |
|  | System options Access to general parameters of the system. |

| | |
|-----------------------------------------------------------------------------------|------------------------------------------------------------------------------------------------------|
|  | Change resolution 1 Allows you to increase the resolution regarding the active display. |
|  | Change resolution 2 Allows you to decrease the resolution regarding the active display. |
|  | Modify angle unit Allow to modify the angle unit. The current active angle unit is degree. |
|  | Modify angle unit Allow to modify the angle unit. The current active angle unit is DMS. |
|  | Modify angle unit Allow to modify the angle unit. The current active angle unit is radian. |
|  | Select Allows you to select all the blocks of the memory |
|  | Deselect Allows you to deselect all the blocks of the memory |
|  | Delete Allows you to delete all the blocks previously selected in the memory |
|  | *.pdf document Creation of the *.pdf document on the USB stick. |

22.2 Actions regarding ST1 & ST2 modes

| Definition | |
|-------------------------------------------------------------------------------------|------------------------------------------------------------------------------------------------------------------------------------------------------------------|
|  | Redefine reference Allows you to restart the process to define the active reference. |
|  | Leave mode 'recall programme' Allows you to stop the current measurement programme (programme recall) |
|  | Calibration of the insert with groove Allows you to define the calibration process of the insert by measurement of a groove. |
|  | ISO table Allows you to display the ISO table of tolerances in order to quickly set the tolerances of the selected value. |
|  | Indirect reference (PRESET) Allows you to take into account an offset regarding the active reference, so that you can work with an indirect reference. |
|  | Probe constant Restarts the calculation procedure of the probe constant. |
|  | Calibration of the insert with rib Allows you to define the calibration process of the insert by measurement of a rib. |



22.3 Actions regarding Angle mode















| Definition | |
|-------------------------------------------------------------------------------------|-----------------------------------------------------------------------------------------------------------------------------------------------------------------------------------------------------------------|
|  | Gage block Allows you to manually enter the size of the standard used in order to calculate the angle of a workpiece. This value is stored in the memory as long as the instrument is not turned off. |

22.4 Actions regarding Min, max, Δ mode



| Definition | |
|-------------------------------------------------------------------------------------|-------------------------------------------------------------------------------------------------------|
|  | Reference Allows you to take the reference into account in your measurement results or not. |

22.5 Actions regarding 2D mode

| Definition | |
|-------------------------------------------------------------------------------------|----------------------------------------------------------------------------------------------------------------------------------------------------------------------------------------------------|
|  | Angle between two lines Allows to calculate the angle between two selected lines. |
|  | Angle by three points Allows to calculate the angle that make three elements represented either by simple points or circles. A combination of these two elements types is also possible. |
|  | Intersection Allows to create the intersection point between two lines. |

| | |
|-------------------------------------------------------------------------------------|----------------------------------------------------------------------------------------------------------------------------------------------------------|
|  | Circle by three points Allows to calculate the perfect circle going through three points, circles or a combination of these two element types. |
|  | Bestfit circle Allows to calculate the best circle from more than three points or circles' centres. |
|  | Line by two points Allows to calculate the perfect line going through two points, circles or a combination of these two elements' types. |
|  | Bestfit line Allows to calculate the best line from three or more points or circles' centres. |
|  | Distance Allows to calculate the distance between two points or circles centres. |
|  | Perpendicular distance Allow to calculate the perpendicular distance between a point/circle and a line. |
|  | Analyse and display results Allows to display measured and calculated data. |
|  | Save result Allows to save a result in the main programme to be run later. |
|  | Y axis as reference Allows to set a line as Y axis datum |
|  | Z axis as reference Allows to set a line as Z axis datum |
|  | Origin Allows to define a point or a circle centre as origin |
|  | Rotate for Y coordinate Allows to rotate the part to measure Y coordinates |
|  | Rotate for Z coordinate Allows to rotate the part to measure Z coordinates |
|  | Coordinate change 1 Switches to Cartesian coordinates |
|  | Coordinate change 2 Switches to polar coordinates |

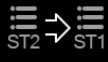
22.6 Actions regarding Calculator mode

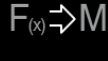
| Definition | |
|-------------------------------------------------------------------------------------|-------------------------------------------------------------------------------------------------------------------|
|  | Change memory Allows you to change from memory ST1 to measurement memory ST2 (or vice versa) |
|  | Get function Allows to recall the customised function from a block |
|  | Customised function Allows you to create a customised calculation block with the previous result blocks |

OPTIONAL ACCESSORIES:



Power supply
00760251



Master piece
00760253



Panel
00760234



TLC-USB cable, 2m
04760181



Printer
00760235



4 paper rolls for printer
00760250



Hand switch
04768000



DATA-DIRECT software
04981001



STAT-EXPRESS software
04981002



Foot switch
04768001

DECLARATION OF CONFORMITY EU

We thank you for purchasing our product. We hereby certify that it was inspected in our works.

Declaration of conformity and confirmation of traceability of indicated values

We declare under our sole responsibility that its quality is in conformity with all technical data as specified in our sales literature (instruction manual, leaflet, general catalogue). In addition, we certify that the measuring equipment used to check this product refers to national standards. Traceability of the measured values is ensured by our Quality Assurance.

Name of manufacturer TESA SA

Address of manufacturer Rue du Bugnon 38
CH – 1020 Renens

Declares under its sole responsibility

The product **MEASURING STATION
TESA μ -HITE**

Type **00730503 TESA μ -HITE
00730502 TESA μ -HITE**

is in compliance with

- the directives 2014/30/EC
- the standards EN 61326, class B, with disconnected charger
- and the continued technical data in our sales documents

Renens, 02 Mai 2016

Quality Assurance Service